



Feel the difference!
Experience the real Comfort

DC INVERTER
TECHNOLOGY

KLIMAIRE

ULTIMATE COOLING & HEATING SOLUTION





What Klimaire brings you . . .

We have been in Ductless mini-split business since 1989 and at Klimaire maintain the highest quality and reliability with ISO 9001 and ISO 14001 standards in our manufacturing facilities. Our products have proven their endurance and resiliency over time operating in 70 different countries since then. All products are ETL certified and AHRI registered.

Klimaire products exceed industry standards for energy efficiency and employs innovative technology to achieve the highest customer satisfaction. Since our goal is to achieve maximum customer satisfaction, we continuously seek to achieve in the design phase of our future units higher performance levels.

Ductless mini-split systems are one of the fastest growing products in the US and popularity is rapidly increasing. They allow air conditioning and heating systems to be added quickly, economically and conveniently, often for some applications where installing comfort systems didn't seem possible or practical.

Flexibility is the main role of their popularity.

Klimaire ductless systems are simple, reliable, and easy to install as well as affordable. These systems are integrated with innovative inverter technology providing individual comfort and control. We are committed to bring you real comfort with our series to our valuable customers where you Like it, when you Like it and how you Like it.

Light Commercial

Experience the true comfort.

Light Commercial systems are perfect solution to variety of installation challenges, allowing installers the ability to place ductless mini-split units in locations that were previously impractical or impossible.

They are ideal when additional ductwork is necessary but not cost effectively.

Basically Ductless mini-split units eliminate the use of ductwork.

In addition to eliminating the need for ducting, one of the other great advantages of light commercial systems is true zone control.

Each indoor fan coil unit is dedicated to the room being conditioned allowing a temperature and humidity level to be kept different from the rest of the house or the building.

The Smart Choice...

The US Department of Energy (DOE) says that as much as half of the energy used in your home goes to heating and cooling. So making smart decisions about your home's heating, ventilating, and air conditioning (HVAC) system can have a big effect on your utility bills and your comfort.

Klimaïre DC Inverter - driven ductless air conditioners and heat pumps can save you up to 33% in your power utility bill when compare with room air conditioners or standard efficiency 10 SEER ductless systems. Even up to 30% energy consumption savings can be achieved when ductless Invertech units are practical to install and preferred over traditional ducted central units. Total savings can reach up to 60% when the two options are combined.

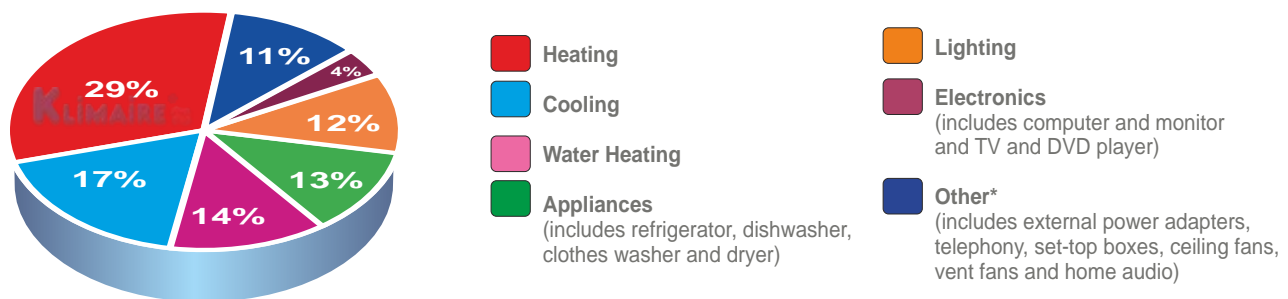

Inverter Technology:

DC Inverter is a type of power conversion circuit that electronically regulates the voltage, current and frequency of a compressor or a motor. DC INVERTER-driven air conditioners and heat pumps bear special double cam, twin rotary variable speed compressor. Like a cruise control of a vehicle. Inverter technology varies the compressor speed based on cooling and heating needs in the space. Variable speed enables to precisely match system capacity to actual load. They can slow down or speed up based on demand load. By varying the speed of the compressor systems are able to better match load in heating and cooling. In multi zone inverter systems the indoor units constantly change capacity and electronically communicate with the Klimaïre outdoor unit to increase or decrease capacity for optimum comfort and save energy. Therefore systems operate more efficiently at light load, while still being capable of increasing the speed to deliver full capacity when needed.

Since humidity is a major factor for comfort, in the summer, Klimaïre DC INVERTER – driven variable speed compressors reduces capacity to match lighter loads increasing the run time to remove moisture and reduce relative humidity resulting in improved comfort. In the winter, by increasing the speed of the compressor Klimaïre air conditioner and heat pump systems are able to maintain capacity and deliver hotter supply air even at low outdoor ambient conditions.

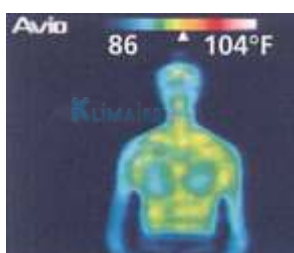

Room temperature 77°F
Humidity 50%

COMFORTABLE
Decreasing humidity while maintaining the temperature increases comfort

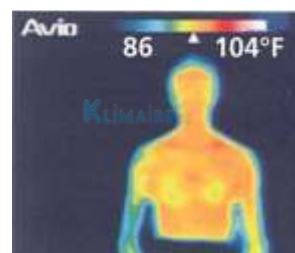

Room temperature 77°F
Humidity 80%

UNCOMFORTABLE
Hot and stuffy with high humidity



Klimaire DC Inverter Technology

Klimaire Inverttech DC inverter -driven air conditioners and heat pumps are the ultimate cooling and heating technology of the HVAC field. Klimaire DC Inverter Technology adopts the new advanced 180 Sine Wave DC inverter driven technology and brushless DC (BLDC) motor (variable revolution) twin cam compressor. This translates into more energy-savings and quieter operation than 120 Square- Wave DC inverter types. Result is more consistent temperature which translates into increased comfort and energy savings all year round.

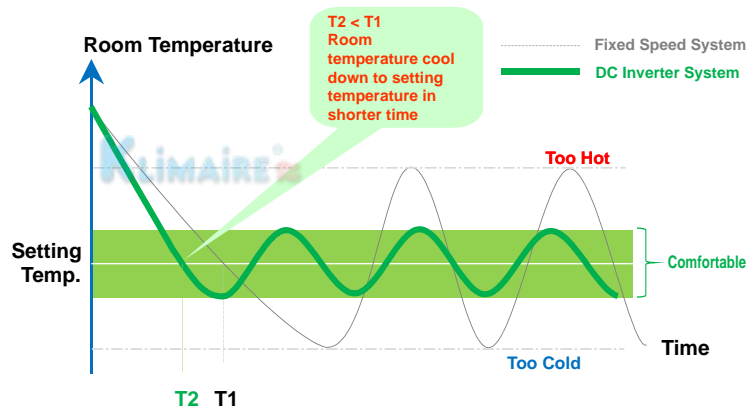

DC Inverter 180 Sine Wave

- 1-Wider frequency & voltage range
- 2-More Efficient & higher savings
- 3-Lower noise & reduced vibration for longer life
- 4-Improved reliable operation

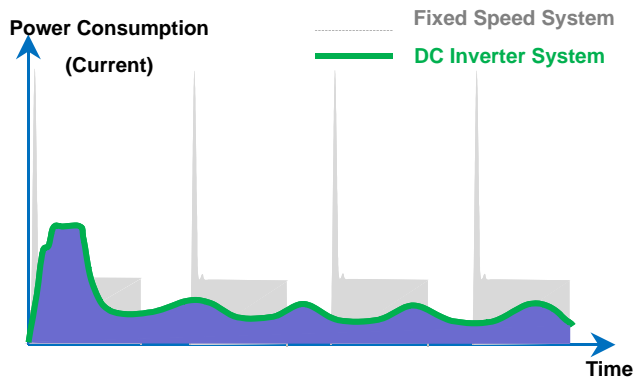

Savings and advantages are even much more when you compare with traditional systems. They run at fixed speed and cycle on/off to match the load. This will result compressor to draw tremendous energy each time when it starts up. On/off cycling also reduces the life-span of the compressor and other components that cycle on/off.



A high performance double cam twin rotary compressor increases the performance, reliability, and durability. Energy savings are much higher with this INVERTECH DC INVERTER - driven variable speed compressor.

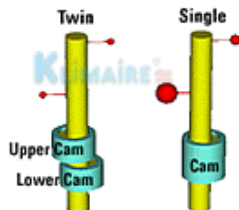

The opposite double blade advanced design provides mechanical stability and less vibration that shall increase the life of compressor and other components in the outdoor unit.



Homeowners and neighbors enjoy quiet whisper breeze outdoor unit operation making sure nobody is disturbed.

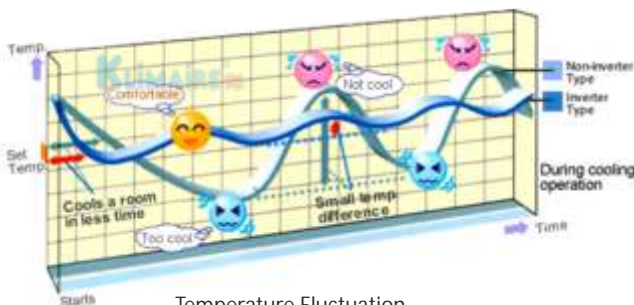

Temperature Fluctuation - INVERTECH System vs. On/off System

The temperature fluctuations are much higher in traditional (on/off cycling) systems compared to inverttech driven inverter systems, which effects human comfort.

Real comfort does not only depend on temperature. Dehumidification process, especially during hot sticky weather is essential and integral part of cooling and inverter systems are the more efficient way to remove moisture and control humidity level.

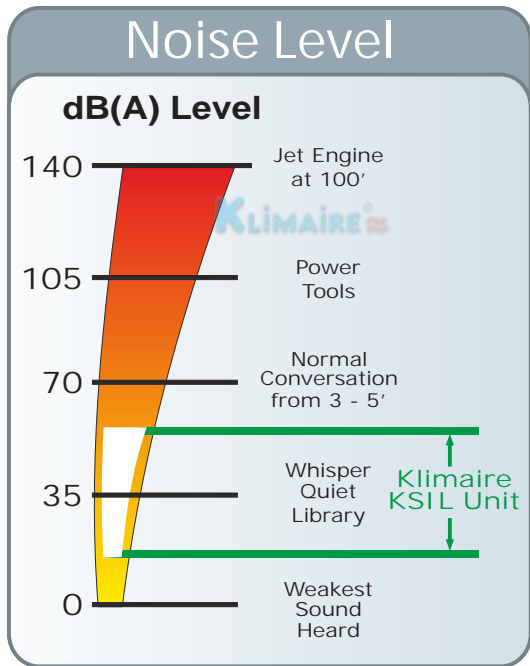

Flexible and Quiet

Like regular split air conditioning or heat pump systems, the condensing unit is installed outdoors allowing a peaceful and more comfortable interior environment.



12,000 - 48,000
KTIM + KSIL



12,000 - 48,000
KUIM + KSIL



12,000 - 48,000
KDIM + KSIL



12,000 btu
KFIM + KSIL



Respected for its reliability Desired for its all season performance

Energy Savings – Reduction of up to 60% in energy consumption can be achieved in comparison to 10 SEER units, which will reduce the utility bill.

Quieter operation – It is less noisy than a self contained window unit, or a packaged terminal unit (PTAC / PTHP), or a central unit. A ductless split system is ultra-quiet because it does not have to push conditioned air through many feet of ductwork, and the noisier outdoor portion of the system operates outdoors.

Comfort – A true temperature control optimizes your comfort. Klimatec INVERTECH advanced DC Inverter technology provides maximum comfort for the entire space by individual temperature and humidity control. By utilizing inverter technology, temperature and humidity fluctuations are minimized, this state-of-the-art electronic climate control also changes the louver direction swings air, to create uniform ambient conditions. When the selected temperature is reached an inverter system runs almost constantly at low economy speed to maintain desired comfort level controlling humidity which is considered vital for comfort.

Powerful – By means of a microprocessor Inverter Technology senses the indoor air temperature of the space being cooled or heated and adjusts the speed of the compressor to run at higher speed to meet the demand and quickly reach the set temperature, then slows down to lower rotation speed to maintain it.

Convenient – Excellent for remodeling older homes, convenient for retrofitting, vacation homes, cabins, classrooms, churches, nursing homes, restaurants, computer rooms, sun rooms, ATMs, office lobbies and remote offices.

Environmentally Friendly – Our units use environmentally friendly R-410A refrigerant designed to prevent the depletion of the ozone layer. Our super high efficiency products contribute to reduce fossil fuel consumption and limit air pollution.



KTIM

The KTIM cassette unit provides cooling and heating capacity with the 360° flow system allows distributing comfort to every corner of the room; additionally it can share this capacity with an adjacent room by means of flex duct connection; exposed decorative panel 4-way distribution. The off-white color blends with any ceiling configuration.

- The removable panel makes the clean process much easier.
- Fresh air intake design
- Easy maintenance built-in drain pump
- Terminals for connecting an alarm and long distance on-off control
- Auto re-start function can be set up on the main PCB
- These units can be installed as a two zone system combined in any of the different available capacities.
- Remote controlled
- Sleep mode
- Grille and indoor unit are shipped in separate boxes
- 12,000 Btu & 18,000 Btu models are available



KDIM

The KDIM hideaway, low profile slim design allows installation above a drop ceiling or attic space easily, no floor space or cabinet build-up required. The unit is less than 9" in height. Back air inlet is standard, and bottom is optional. The bottom and back flange plate size is the same, which makes it easy to exchange installation return air opening from back to bottom. Unit is ideal to cool several zones, such as bedroom and bathroom in residences; foyer, bathroom, and bedroom combinations in commercial applications.

- Standard fresh air hole, easy air duct connection
- Wired control
- Independent dehumidification
- Anti-cold air function
- Sleep mode
- 12,000 Btu & 18,000 Btu models are available



KUIM

The KUIM unique decorative and versatile design allows the unit to be suspended from the ceiling or placed low on the wall or simply placed on the floor. Extremely quiet, and rugged construction makes it ideal for areas of heavy traffic and public areas. They are perfect for residential or commercial applications.

- Attractive, modern design
- Exceptionally quiet operation
- Ease of service and installation
- Anti-cold air function
- Auto restart function
- Auto defrosting
- Sleep mode
- 12,000 Btu & 18,000 Btu models are available



KFIM

Klimaire KFIM console fan coils are designed and engineered to provide with its innovative style years of reliable operation, energy-efficient, and unmatched comfort, and many years of trouble-free performance.

- Wide angle air flow
- Quiet and fashion design
- Air inlet from 4 direction, and two optional air outlet ways
- Low noise, energy saving.
- Sleep mode
- 12,000 Btu & 18,000 Btu models are available



GENERAL SPECIFICATIONS



Light Commercial Series KSIO Outdoor Units

KSIO Outdoor Unit					
Klimaïre Model No.			KSIO012-H223-O	KSIO018-H221-O	KSIO024-H218-OC
Power supply		V- Ph-Hz	230-1-60	230-1-60	230-1-60
Max. fuse		A	15	20	25
Minimum circuit ampacity		A	8	13	15
Outdoor fan motor	Qty		1	1	1
	Speed	r/min	850/580	750/500	850
Outdoor air flow		cfm	1295	1471	2060
Outdoor noise level		dB(A)	55	60,5	61
Throttle type			Capillary	Capillary	Capillary + EXV
Outdoor unit	Dimension (WxDxH)	in	30"-1/8 x 11"-1/8 x 23"-1/4	33"-1/4 x 13"-3/16 x 27"-13/32	35"-3/16 x 12"-3/16 x 33"-7/8
	Packing (WxDxH)	in	35" x 14" x 25"-3/8	38" x 15"-5/8 x 29"-11/16	41" x 15"-5/8 x 36"
	Net/ Gross weight	lb	87 /92.4	104.5 / 112.2	159 /168
Refrigerant type/Quantity	Type		R410A	R410A	R410A
	Charged volume	oz	56,53	61,83	89,6
Design pressure		psig	340	340	340
Refrigerant piping	Liquid side/ Gas side	in	1/4" / 1/2"	1/4" / 1/2"	3/8" / 5/8"
	Max. pipe length	ft	35	98	160
	Max. difference in level	ft	33	65	80
Ambient temperature	Cooling	°F	0 ~ 50	5 ~ 122	5 ~ 122
	Heating	°F	5 ~ 75	5 ~ 75	5 ~ 75

Remarks:1.The above design and specifications are subject to change without prior notice for product improvement.

2.The values given in the table for the noise level reflect the levels in anechoic chamber.

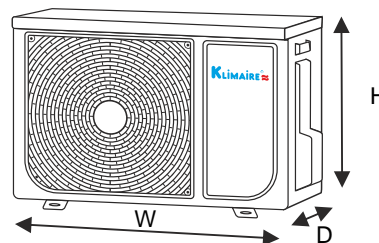

GENERAL SPECIFICATIONS



Light Commercial Series KSIL Outdoor Units

Outdoor Unit			KSIL012-H219-O	KSIL018-H219-O	KSIL024-H219-OC
Power supply	V- Ph-Hz		230-1-60	230-1-60	230-1-60
Max. fuse	A		15	20	25
Minimum circuit ampacity	A		8	13	15
Outdoor fan motor	Qty		1	1	1
	Speed	r/min	850/580	750/500	850
Outdoor air flow	cfm		1295	1471	2060
Outdoor noise level	dB(A)		55	60,5	61
Throttle type			Capillary	Capillary	Capillary + EXV
Outdoor unit	Dimension (WxDxH)	in	30"-1/8 x 11"-1/8 x 23"-1/4	33"-1/4 x 13"-3/16 x 27"-13/32	35"-3/16 x 12"-3/16 x 33"-7/8
	Packing (WxDxH)	in	35" x 14" x 25"-3/8	38" x 15"-5/8 x 29"-11/16	41" x 15"-5/8 x 36"
	Net/ Gross weight	lb	87 /92.4	104.5 / 112.2	159 /168
Refrigerant type/Quantity	Type		R410A	R410A	R410A
	Charged volume	Oz	56,53	61,83	89,6
Design pressure	psig		340	340	340
Refrigerant piping	Liquid side/ Gas side	in	1/4" / 1/2"	3/8" / 5/8"	3/8" / 5/8"
	Max. pipe length	ft	35	98	160
	Max. difference in level	ft	33	65	80
Ambient temperature	Cooling	°F	0 ~ 50	5 ~ 122	5 ~ 122
	Heating	°F	5 ~ 75	5 ~ 75	5 ~ 75

			KSIL036-H215	KSIL048-H216
Power supply	V / ph / Hz		208-230/1/60	208~230-1-60
Max. fuse size	A		50	55
Minimum circuit ampacity	A		30	35
Outdoor fan motor	Qty	n	1	2
	Speed	rpm	860	1000
Outdoor air flow (Max.)	cfm		3240	4240
Outdoor noise level	dB(A)		66	64
Refrigerant gas throttle	Type		Capillary +EXV	Capillary +EXV
Outdoor unit	Dimension (WxDxH)	in	38.98x13.58x37.99	36.93x15.43x53.9
	Packing (WxDxH)	in	44.09x17.13x43.31	43.11x19.49x59.25
	Net/ Gross weight	lb	160.94/182.98	220.46/251.33
Refrigerant gas	Type	oz.	R410A	R410A
	Charge volume	oz.	97	152
Design pressure	psig		550/340	550/340
Refrigerant piping	Liquid side/ Gas side	in	3/8" / 5/8"	3/8" / 5/8"
	Max. pipe length	ft	213	213
	Max. level difference	ft	98	98
Ambient temperature	Cooling	°F	5~122	5~122
	Heating	°F	5~76	5~76

Remarks: 1. The above design and specifications are subject to change without prior notice for product improvement.
 2. The values given in the table for the noise level reflect the levels in anechoic chamber.

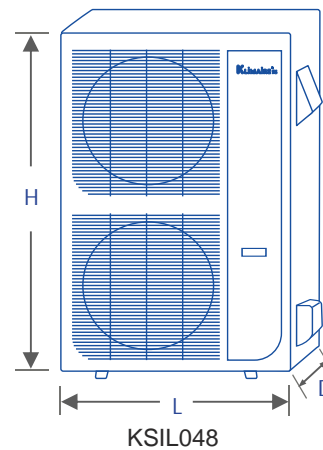
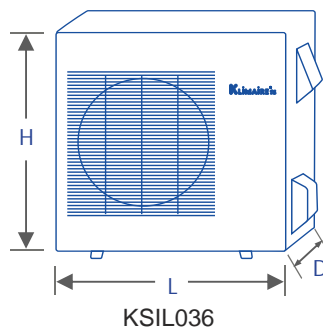
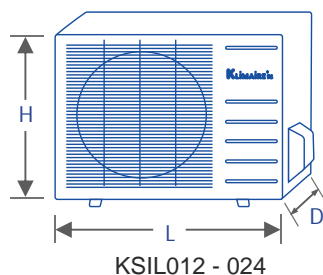

GENERAL SPECIFICATIONS



Light Commercial Series KTIM Indoor Units

Indoor Unit			KTIM012-H2	KTIM018-H2	KTIM024-H2
Klimaite Model No.					
Power supply		V-ph-Hz	208~230-1-60	208~230-1-60	220-1-60
Cooling	Capacity	Btu/h	12.000	18.000	23.800
	SEER		16,5	17	15,8
Heating	Capacity	Btu/h	12.400	18.400	23.800
	HSPF		9,6	8,8	9,5
Indoor fan motor	Qty		1	1	1
	Speed(Hi/Med/Lo)	r/min	760/730/620	760/730/620	580±20
Unit Dimensions	Chassis (WxDxH)	in	22"-7/16 x 22"-7/16 x 10"-1/4	22"-7/16 x 22"-7/16 x 10"-1/4	33"-1/16 x 33"-1/16 x 8"-1/16
	Packing (WxDxH)	in	25"-25/32 x 25"-25/32 x 11"-7/16	25"-25/32 x 25"-25/32 x 11"-7/16	35"-7/16 x 35"-7/16 x 8"-7/8
	Panel (WxDxH)	in	25"-15/32 x 25"-15/32 x 1"-31/32	25"-15/32 x 25"-15/32 x 1"-31/32	37"-13/32 x 37"-13/32 x 2"-3/16
	Packing (WxDxH)	in	28"-1/8 x 28"-1/8 x 4"-27/32	28"-1/8 x 28"-1/8 x 4"-27/32	40"-3/4 x 40"-3/4 x 3"-1/2
	Chassis Net/Gross weight	lb	35.2 / 41.8	39.6 / 46.2	45.1 / 52.8
	Panel Net/Gross weight	lb	5.5 / 9.9	5.5 / 9.9	11 / 17.6
Design pressure		psig	340	340	340
Drainage water pipe diameter		in	OD 1/4	OD 1/4	OD 1"-1/4
Refrigerant piping	Liquid side/Gas side	in	1/4" / 1/2"	3/8" / 5/8"	3/8" / 5/8"
Controller			RG05F2/BGEU1	RG05F2/BGEU1	RG05F2/BGEU1
Operation	Cooling	°F	?63	?63	?63
Temperature	Heating	°F	?86	?86	?86

Indoor Unit Model Number			KTIM036-H2	KTIM048-H2
Power supply		V /ph / Hz	208~230-1-60	208~230-1-60
Cooling	Capacity	Btu/h	36.000	46.000
	SEER	—	15	15,5
Heating	Capacity	Btu/h	36.000	47.000
	HSPF	—	9,0	9,0
Indoor fan motor	Qty	n	1	1
	Speed (Hi/Med/Lo)	rpm	720/630/560	720/630/560
Indoor unit	Dimension (W x Dx H)	in	33.07x33.07x9.65	33.07x33.07x11.3
	Packing (W x Dx H)	in	35.43x35.43x10.43	35.43x35.43x11.5
	Panel Dimension (W x Dx H)	in	37.4x37.4x2.17	37.4x37.4x2.17
	Panel Packing (W x Dx H)	in	40.75x40.75x3.54	40.75x40.75x3.54
	Unit Net/Gross weight	lb	55.12/62.83	63.93/73.85
	Panel Net/Gross weight	lb	11.02/17.64	11.02/17.64
Design pressure		psig	550/340	550/340
Drainage water pipe dia.		in	OD 1"-1/4	OD 1"-1/4
Refrigerant lines	Liquid / Gas	in	3/8" / 5/8"	3/8" / 5/8"
Controller		—	RG05F2/BGEU1	RG05F2/BGEU1
Room temperature	Cooling	?	62 ~ 90	62 ~ 90
	Heating	?	32 ~ 86	32 ~ 86
Operation temperature		?	62~86	62~86

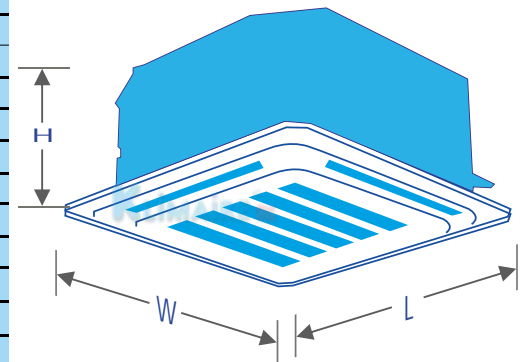

Remarks: 1. The above design and specifications are subject to change without prior notice for product improvement.
 2. The values given in the table for the noise level reflect the levels in anechoic chamber.

GENERAL SPECIFICATIONS



Light Commercial Series KUIM Indoor Units

Indoor Unit			KUIM012-H2	KUIM018-H2	KUIM024-H2
Klimaite Model No.					
Power supply		V-ph-Hz	208~230-1-60	208~230-1-60	220-1-60
Cooling	Capacity	Btu/h	12.000	18.000	25.000
	SEER		19	16	17
Heating	Capacity	Btu/h	12.400	18.400	26.000
	HSPF		9,1	8,5	8,9
Indoor fan motor	Qty	n	1	1	1
	Speed(Hi/Med/Lo)	r/min	1300±20	1300±20	1300±20
Indoor unit	Dimension (WxDxH)	in	39" x 26" x 8"	39" x 26" x 8"	42" x 26"-9/16 x 9"-1/4
	Packing (WxDxH)	in	42"-29/32 x 29"-5/16 x 11"-11/16	42"-29/32 x 29"-5/16 x 11"-11/16	45"-1/16 x 29"-23/32
	Net/Gross weight	lb	48.4 / 61.6	52.8 / 66	55 / 66
Design pressure		psig	340	340	340
Drainage water pipe diameter		in	1"	1"	1"
Refrigerant piping	Liquid side/Gas side	in	1/4" / 1/2"	3/8" / 5/8"	3/8" / 5/8"
Controller			RG05F2/BGEU1	RG05F2/BGEU1	RG05F2/BGEU1
Operation temperature	Cooling	°F	?63	?63	?63
	Heating	°F	?86	?86	?86

Indoor unit model number			KUIM036-H2	KUIM048-H2
Power supply		V/ph/Hz	208-230/1/60	208-230/1/60
Cooling	Capacity	Btu/h	36.000	48.000
	SEER	—	15	16
Heating	Capacity	Btu/h	36.000	49.000
	HSPF	—	9,0	10,0
Indoor fan motor	Quantity	n	1	2
	Speed (Hi/Med/Lo)	rpm	1300/1150/800	1320/1200/1120
Indoor unit	Dimension (WxDxH)	in	50.59x26.57x9.25	64.96x26.57x9.25
	Packing (WxDxH)	in	53.54x29.72x12.32	67.91x29.72x12.32
	Net/Gross weight	lb	66.14/77.16	83.78/97
Design pressure		psig	550 / 340	550 / 340
Drainage water pipe diameter		in	OD 1"	OD 1"
Refrigerant piping	Liquid /Gas	in	3/8" / 5/8"	3/8" / 5/8"
Controller		—	RG05F2/BGEU1	RG05F2/BGEU1
Room temperature	Cooling	?	62 ~ 90	62 ~ 90
	Heating	?	32 ~ 86	32 ~ 86

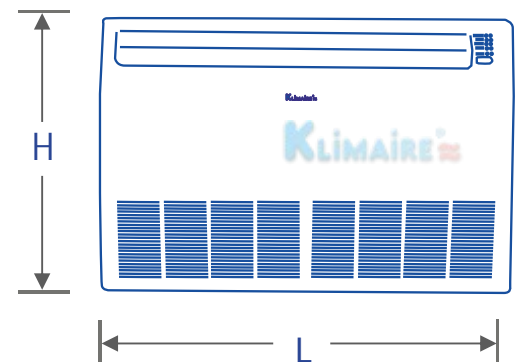

Remarks: 1. The above design and specifications are subject to change without prior notice for product improvement.
 2. The values given in the table for the noise level reflect the levels in anechoic chamber.

GENERAL SPECIFICATIONS



Light Commercial Series

KFIM Indoor Units

Indoor Unit		
Klimaite Model No.		KFIM012-H2
Power supply	V-ph-Hz	208~230-1-60
Cooling	Capacity	Btu/h 12.000
	SEER	17,6
Heating	Capacity	Btu/h 12.000
	HSPF	10
Indoor fan motor	Qty	1
	Input	W 28
	Capacitor	uF /
	Speed(Hi/Med/Lo)	rpm 890/840/780/680/530
Indoor unit	Dimension (W x Dx H)	in 27"-9/16 x 23"-5/8 x 8"-1/4
	Packing (W x Dx H)	in 31"-29/32 x 27"-31/32 x 12"
	Net/Gross weight	lb 33 / 44
Design pressure	psig	340
Drainage water pipe dia.	in	OD 5/8
Refrigerant piping	Liquid side/ Gas side	in 1/4" / 1/2"
Controller		RG05F2/BGEU1
Operation temperature	Cooling	°F ?63
	Heating	°F ?86

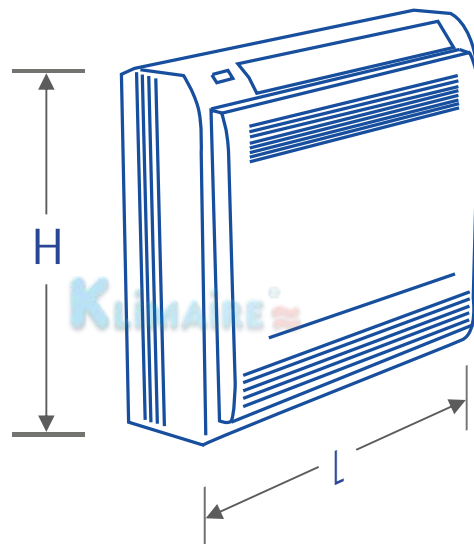

Remarks:1.The above design and specifications are subject to change without prior notice for product improvement.
2.The values given in the table for the noise level reflect the levels in anechoic chamber.

GENERAL SPECIFICATIONS



Light Commercial Series

KDIM Indoor Units

Ducted Recessed

Klima Model No.			KDIM012-H2	KDIM018-H2	KDIM024-H2
Power supply		V-ph-Hz	208~230-1-60	208~230-1-60	220-1-60
Cooling	Capacity	Btu/h	12.000	18.000	24.000
	SEER		15,5	15,5	16,5
Heating	Capacity	Btu/h	12.200	18.600	25.000
	HSPF		9,3	8,6	8,2
		Qty	1	1	1
Indoor fan motor	Input	W	71/48.8/36.7	119/56/43	90
	Capacitor	uF	2UF/450V	3.5UF/450V	\
	Speed(Hi/Med/Lo)	rpm	1255/1005/850	1170/790/690	1000±20
Indoor external static pressure (Hi)		Pa	40	70	70
Indoor noise level (Hi/Med/Lo)		dB(A)	38/36/32	42/36/32	49/47/44
Indoor unit	Dimension (WxDxH)	in	27"-9/16 x 25" x 8"-17/64	36"-7/32 x 25" x 8"-17/64	36"-7/32 x 25" x 10"-5/8
	Packing(WxDxH)	in	36" x 25"-25/32 x 11"-3/8	44"-11/16 x 25"-25/32 x 11"-3/8	44"-11/16 x 25"-25/32 x 13"-25/32
	Net/Gross weight	lb	44 / 55	51 / 64	66 / 77
Design pressure		psig	340	340	340
Drainage water pipe diameter		in	1/2	1/2	1/2
Refrigerant piping	Liquid side/ Gas side	in	1/4" / 1/2"	3/8" / 5/8"	3/8" / 5/8"
Controller			KJR-10B/DP(T)-F	KJR-10B/DP(T)-F	KJR-10B/DP(T)-F
Operation temperature	Cooling	°F	?63	?63	?63
	Heating	°F	?86	?86	?86

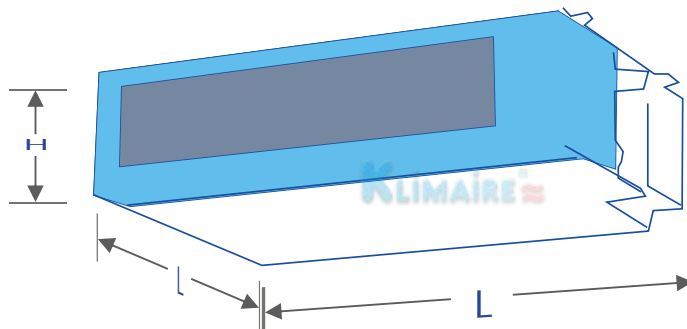

Remarks: 1. The above design and specifications are subject to change without prior notice for product improvement.
 2. The values given in the table for the noise level reflect the levels in anechoic chamber.

5 Year
Warranty
on Compressor

1 Year
Warranty
on Parts

DC INVERTER



2190 NW 89 Place
Doral, FL 33172 – USA

Tel: (305)594-4972 - Fax (305) 499-4378
www.klimaire.com - sales@klimaire.com

KLIMAIRE