

KIDT-KOIT

SERIES

CENTRAL DUCTED **AIR CONDITIONER / HEAT PUMP**

Service Manual

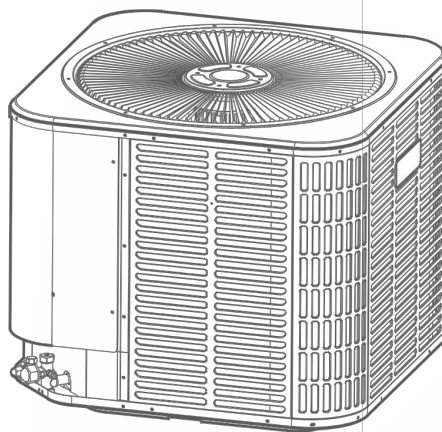
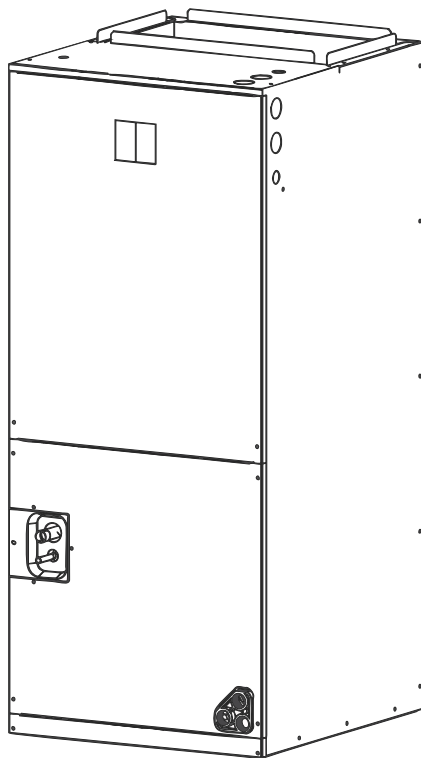

Models Covered:

Indoor Unit

Outdoor Unit

KIDT24H2-41X		KOIT24H2-41G
KIDT36H2-41X		KOIT36H2-41G
KIDT48H2-41X		KOIT48H2-41G
KIDT60H2-41X		KOIT60H2-41G

KLIMAIRE[®]
Mark of Superior Quality

IMPORTANT NOTE:

Read this manual carefully before installing or operating your new air conditioning unit. Be sure to keep this manual for future reference. For more information, please visit www.klimaire.com



Scan the QR code to visit our Help Center for installation guides, manuals, videos and more.



S7DT2603

Contents

1. Product Selection guidebook	4
1.1 Product list	4
1.1.1 Indoor unit lineup	4
1.1.2 Outdoor unit lineup	4
1.1.3 List of standard and optional parts	5
1.2 Nomenclature	6
1.2.1 Nomenclature of outdoor unit	6
1.2.2 Nomenclature of indoor unit	7
1.3 Product parameters	8
1.4 Air volume static pressure curve.....	12
1.5 Noise.....	14
1.5.1 Indoor unit.....	14
1.5.2 Outdoor unit.....	15
2. Installation manual.....	16
2.1 Installation preparation	16
2.1.1 Notice on installation.....	16
2.1.2 Unit dimension	23
2.1.3 Diagram of unit installation space	24
2.2 Unit installation.....	26
2.2.1 Indoor unit installation	26
2.2.2 Outdoor unit installation	31
2.2.3 Piping connection.....	31
2.2.4 Vacuum and leak detection.....	37
2.2.5 Refrigerant adding.....	38
2.2.6 Installation of drain pipe	39
2.2.7 Installation of the duct.....	41
2.3 Electrical installation	43
2.3.1 Requirement and notice of electrical installation.....	43
2.3.2 Electrical parameters	46
2.3.3 Connection of power cord and communication cord	47
2.4 Check after installation	49
2.5 Test running	49
3. Maintenance instruction manual	51
3.1 Control	54
3.1.1 Operation mode	54
3.1.2 Control mode	54
3.1.3 Functions	56
3.2 Troubleshooting	58
3.2.1 Wiring diagrams	58
3.2.2 PCB Layout.....	60
3.2.3 Error codes.....	62
3.2.4 Troubleshooting	65
3.2.5 Failures not caused by error	87
3.3 maintenance	88
3.3.1 System diagram	88

3.3.2 Connection pipe vacuum pumping	89
3.3.3 Refrigerant charging	89
3.3.4 Maintenance of major components.....	90
3.3.5 Removal of major components	91
3.3.6 Exploded view and parts list	99
3.4 Appendices.....	107
3.4.1 Resistance / Temperature list of sensors.....	107
3.4.2 Temperature / Pressure list of Refrigerant	112
3.4.3 Operation tools	112



1. Product selection guidebook

1.1 Products list

1.1.1 Indoor unit lineup

Model	Nominal Capacity Cooling/Heating	Power Supply (V, Ph, Hz)	Appearance	Features
KIDT24H2-41X	24000/24000 (Btu/h)	208-230V~ 1 ph 60Hz		R454B ecofriendly refrigerant Constant torque motor, max. static pressure 200Pa Compatible with 24V&RS485 communication
KIDT36H2-41X	34000/36000 (Btu/h)	208-230V~ 1 ph 60Hz		
KIDT48H2-41X	47000/47000 (Btu/h)	208-230V~ 1 ph 60Hz		Built-in thermal expansion valve Built-in refrigerant leakage sensor Aluminum tube heat exchanger
KIDT60H2-41X	53000/54000 (Btu/h)	208-230V~ 1 ph 60Hz		

1.1.2 Outdoor unit lineup

Model	Nominal Capacity Cooling/Heating	Power Supply (V, Ph, Hz)	Appearance	Features
KOIT24H2-41G	24000/24000 (Btu/h)	208-230V~ 1 ph 60Hz		R454B ecofriendly refrigerant Constant torque motor, max. static pressure 200Pa Compatible with 24V&RS485 communication
KOIT36H2-41G	34000/36000 (Btu/h)	208-230V~ 1 ph 60Hz		
KOIT48H2-41G	47000/47000 (Btu/h)	208-230V~ 1 ph 60Hz		Built-in thermal expansion valve Built-in refrigerant leakage sensor Aluminum tube heat exchanger
KOIT60H2-41G	53000/54000 (Btu/h)	208-230V~ 1 ph 60Hz		

1.1.3 List of standard and optional parts

OPTIONAL PARTS		24K	36K	48K	60K
Wired Controller XK-120D2	Model	XK-120D2	XK-120D2	XK-120D2	XK-120D2
	Product code	22014-000017	22014-000017	22014-000017	22014-000017
Communication Wire between Indoor Unit and Wire Controller (15m)	Specification	15m with connectors	15m with connectors	15m with connectors	15m with connectors
	Product code	22007-001592	22007-001592	22007-001592	22007-001592
Communication Wire between Indoor Unit and Wire Controller (30m)	Specification	30m with connectors	30m with connectors	30m with connectors	30m with connectors
	Product code	22007-001593	22007-001593	22007-001593	22007-001593
Communication Wire between Indoor Unit and Wire Controller (50m)	Specification	50m with connectors	50m with connectors	50m with connectors	50m with connectors
	Product code	22007-001594	22007-001594	22007-001594	22007-001594
Communication Wire between Indoor Unit and Outdoor Unit (15m)	Specification	15m with connectors	15m with connectors	15m with connectors	15m with connectors
	Product code	22007-001595	22007-001595	22007-001595	22007-001595
Communication Wire between Indoor Unit and Outdoor Unit (30m)	Specification	30m with connectors	30m with connectors	30m with connectors	30m with connectors
	Product code	22007-001596	22007-001596	22007-001596	22007-001596
Communication Wire between Indoor Unit and Outdoor Unit (50m)	Specification	50m with connectors	50m with connectors	50m with connectors	50m with connectors
	Product code	22007-001597	22007-001597	22007-001597	22007-001597
Water tray for upside-down installation	Model	/	/	/	/
	Product code	43401-000073	43401-000073	H0221-110017	H0221-110017

1.2 Nomenclature

1.2.1 Klimaire KOIT Outdoor Unit Nomenclature

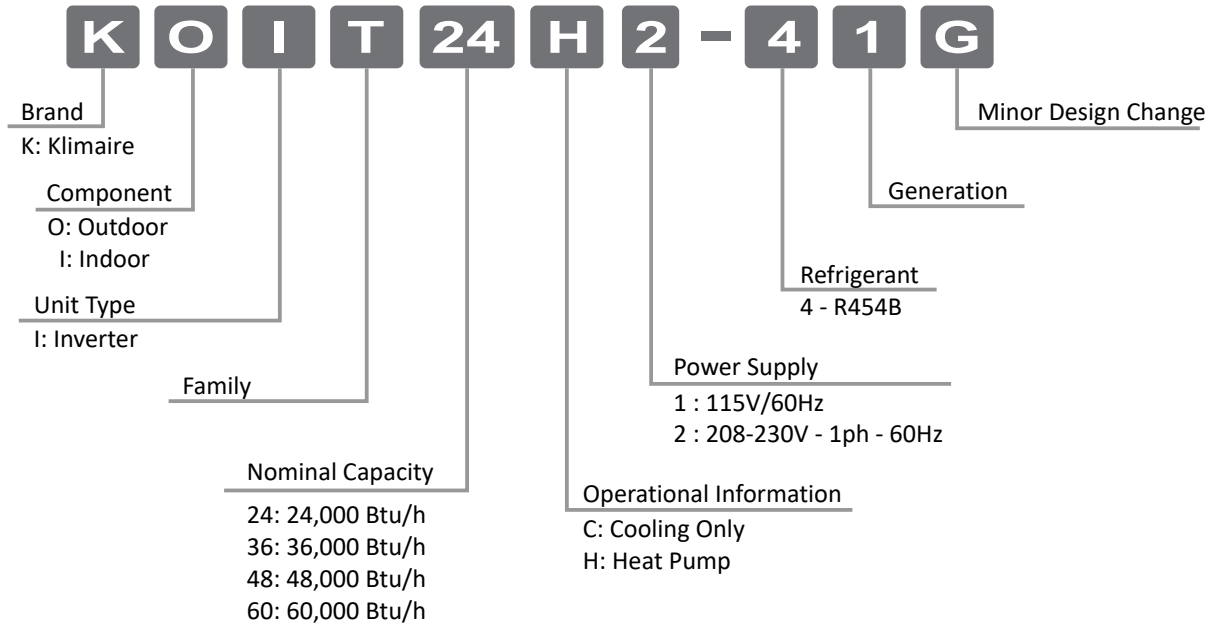

1.2.2 Klimate KIDT Indoor Unit Nomenclature

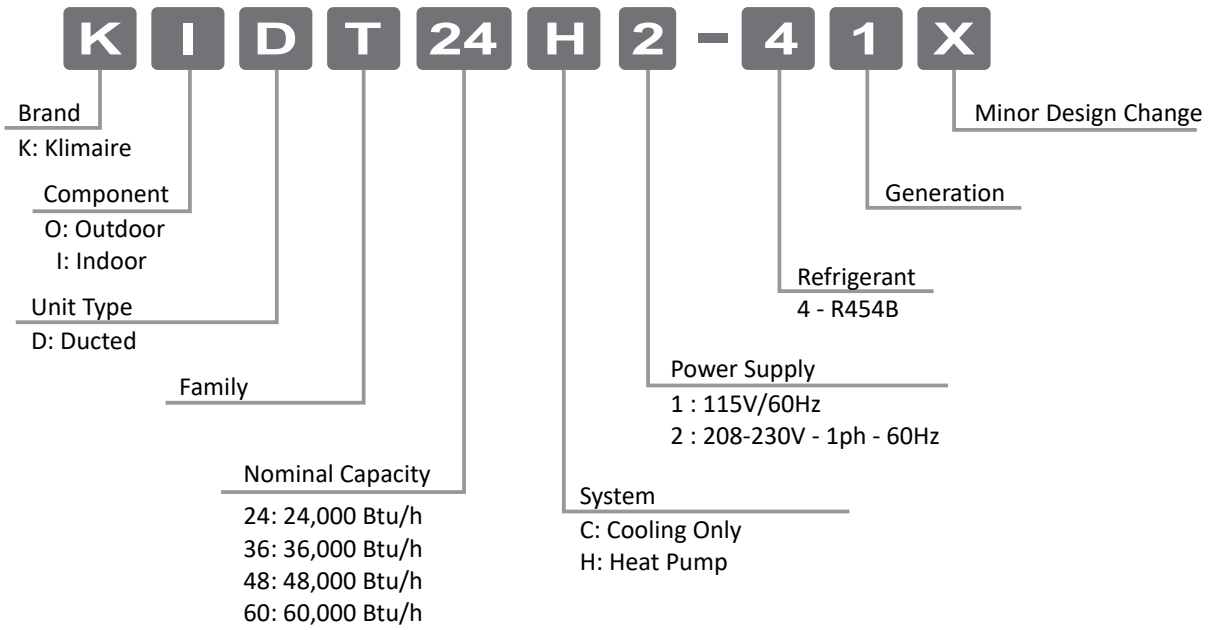

1.3 Product parameters

Factory Model	Indoor Model		KIDT24H2-41X	KIDT36H2-41X	KIDT48H2-41X	KIDT60H2-41X
	Outdoor Model		KOIT24H2-41G	KOIT36H2-41G	KOIT48H2-41G	KOIT60H2-41G
Rated Cooling (95F/35°C)	Capacity	Btu/h	24,000	34,000	47000	53,000
	EER2	Btu/h.W	10.0	10.0	10.0	8.0
	SEER2	Btu/h.W	18.0	19.0	18.0	17.0
Rated Heating (47F/8.3°C)	Capacity	Btu/h	24,000	36,000	47,000	54,000
	HSPF2-4	Btu/h.W	9.0	9.0	8.5	8.5
Cold Climate Heating (5F/-15°C)	Capacity	Btu/h	18,000.0	26,000.0	36,000	38,000
	COP	W/W	1.85	1.85	1.85	1.85
	5F/47F		75%	76%	77%	72%
Operating temperatures	Cooling	°C	-15—52°C	-15—52°C	-15—52°C	-15—52°C
		°F	5—125°F	5—125°F	5—125°F	5—125°F
	Heating	°C	-20—27°C	-20—27°C	-20—27°C	-20—27°C
		°F	-5—80°F	-5—80°F	-5—80°F	-5—80°F
Outdoor Electrical Data	Voltage-Phase-Hz		208/230V -1PH-60Hz	208/230V -1PH-60Hz	208/230V -1PH-60Hz	208/230V -1PH-60Hz
	Minimum Circuit Ampacity	A	20	22	34	34
	Max. Over Current protection (MAX FUSE OR HACR BREAKER)	A	30	35	50	60
	min/max Volts	V	187/253	187/253	187/253	187/253
Outdoor Compressor	Model		KTM240D43U MT	MTD280SKPC 8LT8C	MTH420SKPC 8FQ	MTH420SKPC 8FQ
	Brand		GMCC	HIGHLY	HIGHLY	HIGHLY
	Capacity	Btu/h	23269.8	27705.4	40091.0	40091.0
	Input	W	1805.0	2470.0	3566.0	3566.0
	RLA	A	8.2	10.0	15.8	15.8
	Refrigerant oil	ml	VG74 620ml	HAF68D1C 850ml	HAF68D1C 1150ml	HAF68D1C 1150ml
Outdoor Fan motor	Model/Type		ZW511D000018 L	ZW511D000018 L	ZW511D000018 L	ZW511D000018 L
	Brand		Broad-Ocean	Broad-Ocean	Broad-Ocean	Broad-Ocean

	Type		DC	DC	DC	DC
	Input	W	200	200	200	200
Outdoor Blower	Diameter	inch	23-1/2'	23-1/2'	20-7/8'	20-7/8'
	Width	inch	4-1/2'	4-1/2'	6-3/4'	6-3/4'
Outdoor Coil	Number of rows		1	2	2	2
	Number of U tube		14	28	37	37
	Tube pitch(a)x row pitch(b)	mm	12.7/21	12.7/21	12.7/21	12.7/21
	Fin spacing /thickness/type	mm	1.2/0.095/ hydrophilic aluminium corrugated	1.4/0.095/ hydrophilic aluminium corrugated	1.4/0.095/ hydrophilic aluminium corrugated	1.4/0.095/ hydrophilic aluminium corrugated
	Tube outside dia. and type	mm	inner grooved copper tube/7mm	inner grooved copper tube/7mm	inner grooved copper tube/7mm	inner grooved copper tube/7mm
	Coil length x height x width	mm	2080*588*18.2	2080*588*36.4	2080*798*36.4	2080*798*36.4
	Number of circuits		4	8	11	11
Outdoor Sound Pressure rating		dB	67	68	69	70
Outdoor Throttle type			EEV-1.8	EEV-2.5	EEV-3.2	EEV-3.2
Outdoor Pre-Charged refrigerant		Type	R454B	R454B	R454B	R454B
		oz	75.8	100.5	141.1	141.1
		g	2150	2850	4000	4000
Outdoor Unit Connection Size	Liquid side (Nut Screw)	inch	3/8'	3/8'	3/8'	3/8'
	Suction side (Nut Screw)	inch	3/4'	3/4'	3/4'	3/4'
	Liquid side (Welding)	inch	3/8'	3/8'	3/8'	3/8'
	Suction side (Welding)	inch	3/4'	3/4'	7/8'	7/8'
Outdoor Unit Dimension	Dimension (W x H x D)	inch	29-1/8 x 24-15/16 x 29-1/8	29-1/8 x 24-15/16 x 29-1/8	29-1/8x33-3/16x29-1/8	29-1/8x33-3/16x29-1/8
	Packing (W x H x D)	inch	30-1/5 x 31-1/4 x 30-1/5	30-1/5 x 31-1/4 x 30-1/5	30-1/5 x 39-1/2 x 30-1/5	30-1/5 x 39-1/2 x 30-1/5
Outdoor Unit Weight		kg	62	66	81	81

		lbs	137	146	179	179
Outdoor Ship Weight(Pallet)		kg	72	80	97	97
		lbs	159	176	214	214
Outdoor Shipping per STD40HQ			135	135	90	90
Indoor Electrical Data	Voltage-Phase-Hz		208/230V -1PH-60Hz	208/230V -1PH-60Hz	208/230V -1PH-60Hz	208/230V -1PH-60Hz
	Minimum Circuit Ampacity	A	3.5	5	7.0	7.0
	Max. Over Current Protection	A	15	15	15	15
	Min/Max Volts	V	187/253	187/253	187/253	187/253
Indoor Fan motor	Part Number		22001-000656	22001-000656	22001-000657	22001-000657
	Brand		Broad-Ocean	Broad-Ocean	Broad-Ocean	Broad-Ocean
	Output Power	HP	1/2	1/2	3/4	3/4
	FLA	A	4	3.8	5.5	5.5
Indoor Blower	Diameter	inch	12-1/4'	12-1/4'	12-1/4'	12-1/4'
	Width	inch	13'	13'	13'	13'
Indoor coil	Number of rows		4*2	4*2	5*2	5*2
	Number of U tube		40*2	40*2	60*2	60*2
	Tube pitch(a)x row pitch(b)	mm	21/12.7	21/12.7	21/12.7	21/12.7
	Fin spacing /thickness/type	mm	1.5/0.095/ hydrophilic aluminium Louvered	1.5/0.095/ hydrophilic aluminium Louvered	1.5/0.095/hydr ophilic aluminium Louvered	1.5/0.095/hydr ophilic aluminium Louvered
	Tube outside dia. and type	mm	inner grooved aluminum tube/7mm	inner grooved aluminum tube/7mm	inner grooved aluminum tube/7mm	inner grooved aluminum tube/7mm
	Coil length x height x width	mm	420*410*50.8	420*410*50.8	660*410*50.8	660*410*50.8
	Number of circuits		4*2	4*2	6*2	6*2
Indoor Sound Pressure rating		dB(A)	57	58	60	62
Indoor fan Air flow		CFM	850	1150	1500	1700

		m3/h	1450	1955	2550	2890
Indoor Static Pressure		in.WC	up to 0.8	up to 0.8	up to 0.8	up to 0.8
		Pa	up to 200	up to 200	up to 200	up to 200
Indoor Throttle type	Throttle type		TXV	TXV	TXV	TXV
	Model		3TR	3TR	5TR	5TR
Indoor Refrigerant Connection Size	Liquid side	inch	3/8'	3/8'	3/8'	3/8'
	Suction side	inch	3/4'	3/4'	7/8'	7/8'
Indoor Unit Dimension	Dimension (W*H*D)	inch	21'x46-1/2'x21'	21'x46-1/2'x21'	21'x56'x24-1/2'	21'x56'x24-1/2'
	Packing (W*H*D)	inch	23'x52'x24-1/2'	23'x52'x24-1/2'	24-1/2'x62'x28'	24-1/2'x62'x28'
Indoor Equipment Weight		kg	55.5	55.5	69	69
		lbs	122	122	152	152
Indoor Ship Weight(Pallet)		kg	70	70	86	86
		lbs	154	154	190	190
Indoor Shipping per STD40HQ		unit	152	152	57	57
Refrigerant Pipe Size	Liquid side	inch	3/8'	3/8'	3/8'	3/8'
	Suction side	inch	3/4'	3/4'	7/8'	7/8'
Standard pipe length		m	7.6	7.6	7.6	7.6
		feet	25	25	25	25
Maximum pipe length		m	30	30	30	30
		feet	100	100	100	100
Maximum height difference		m	15	15	15	15
		feet	50	50	50	50

1.4 Air volume static pressure curve

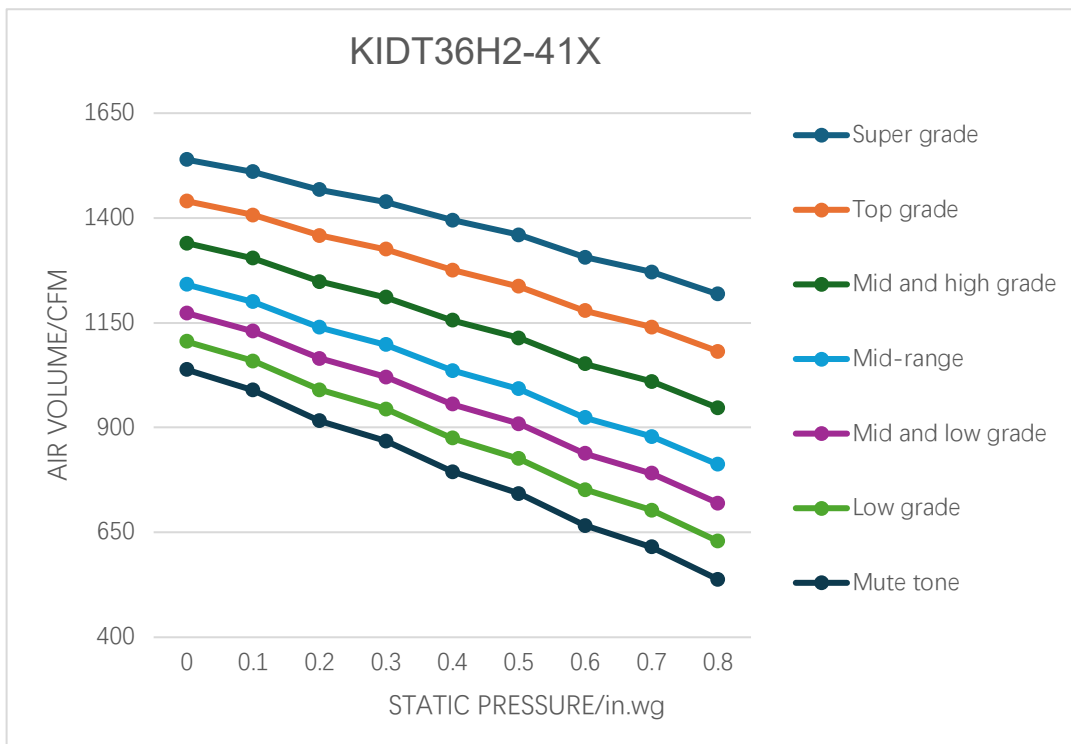
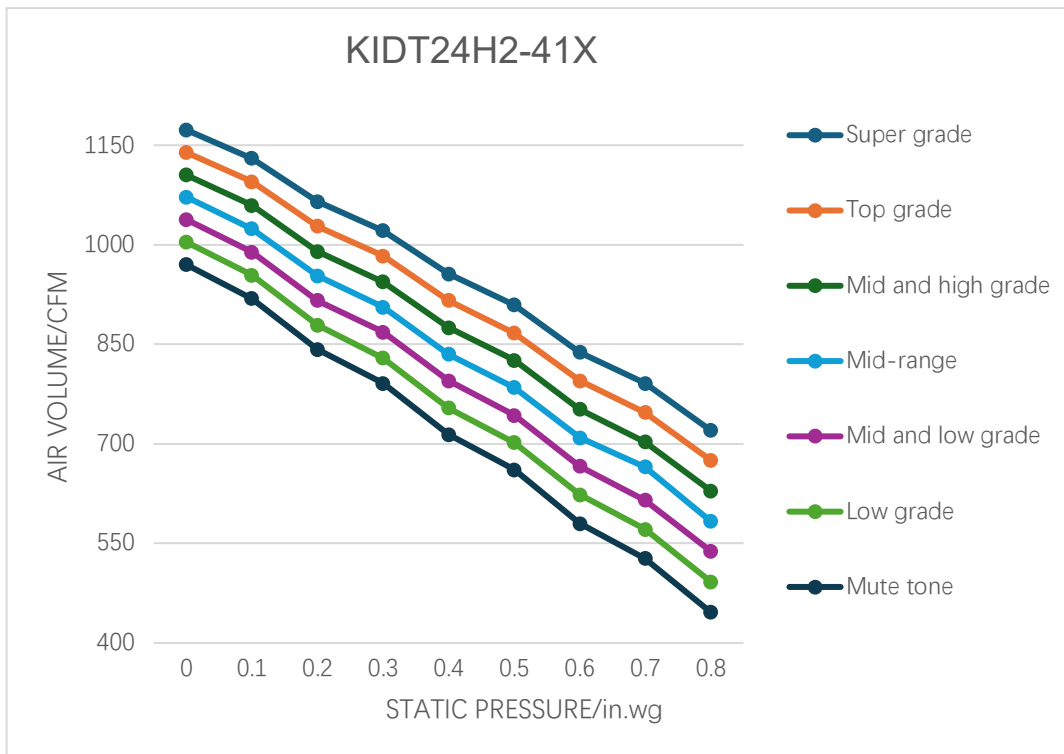

KIDT48H2-41X

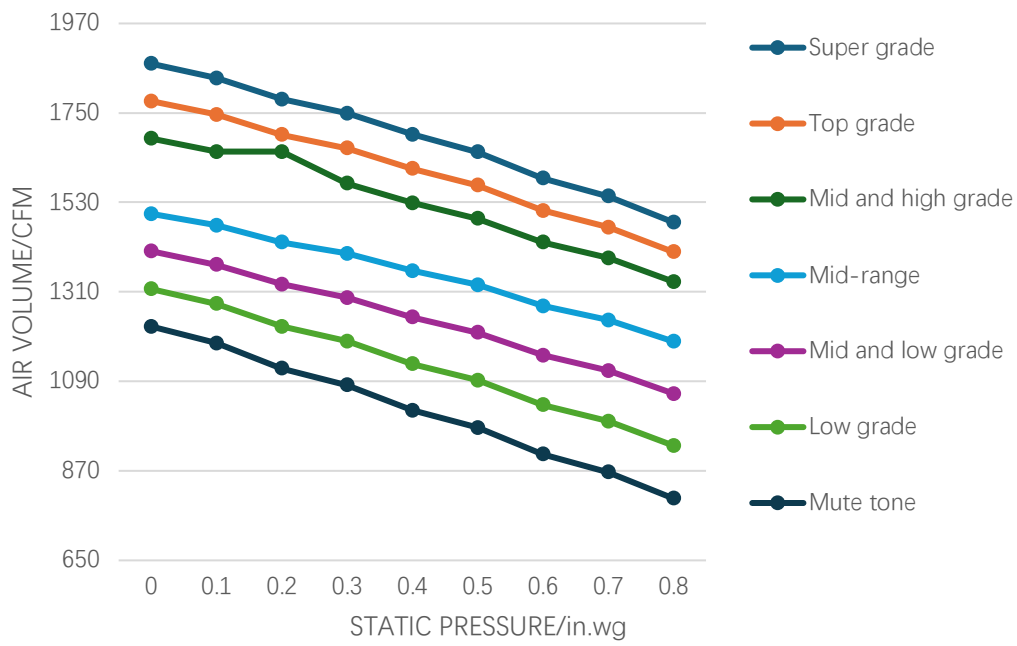

KIDT60H2-41X

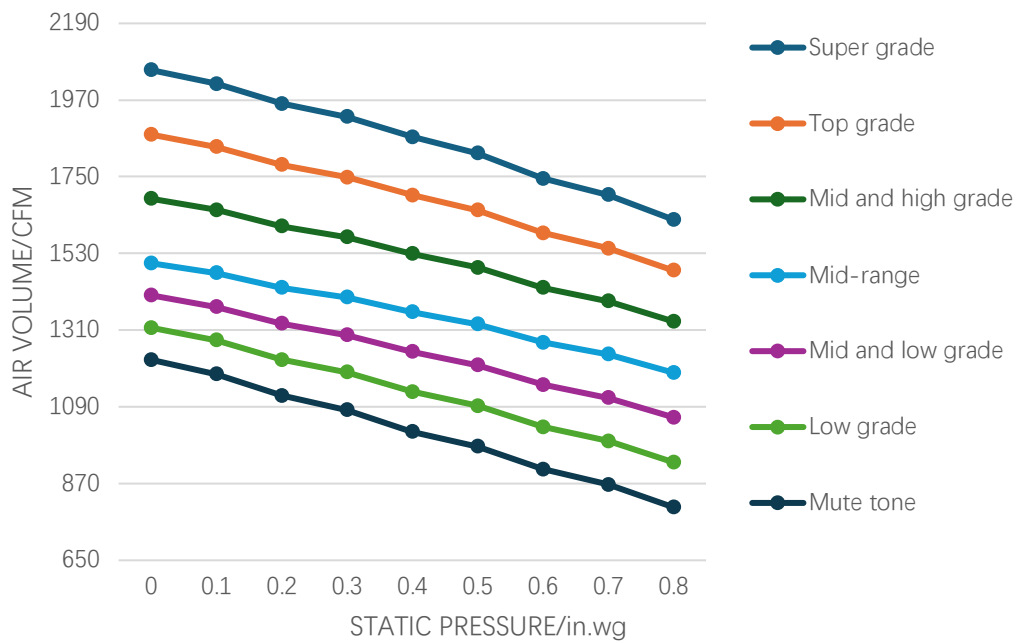

1.5 Noise

1.5.1 Indoor unit

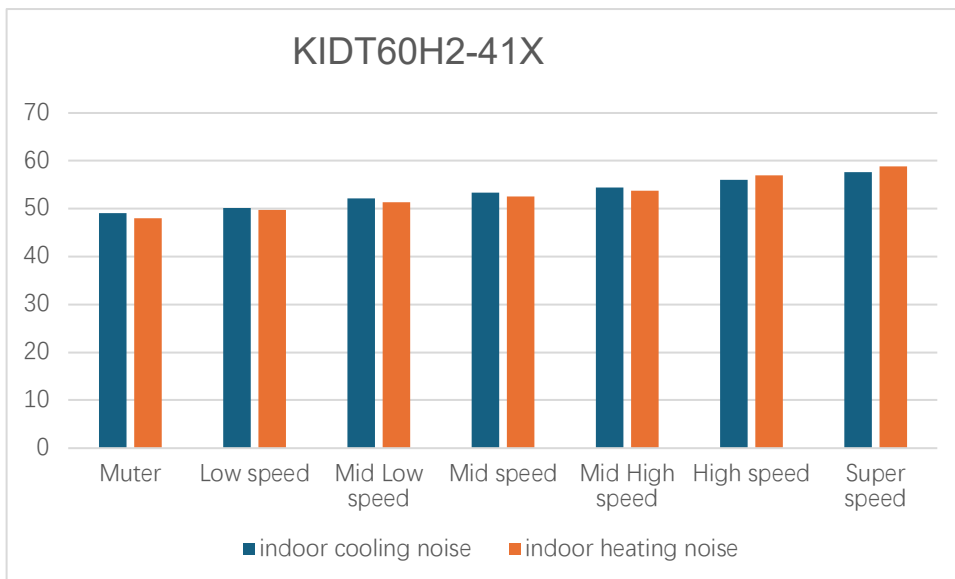
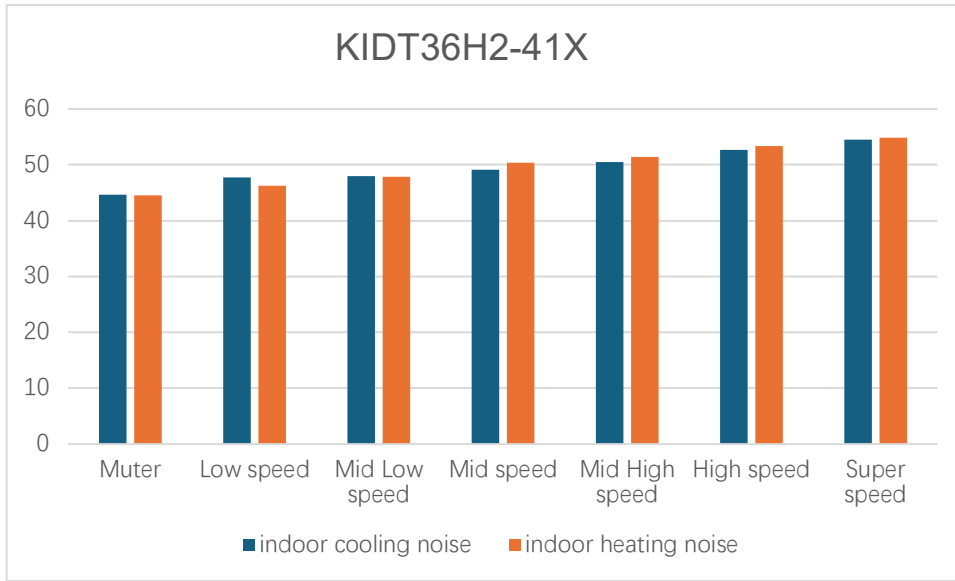

1.5.2 Outdoor unit

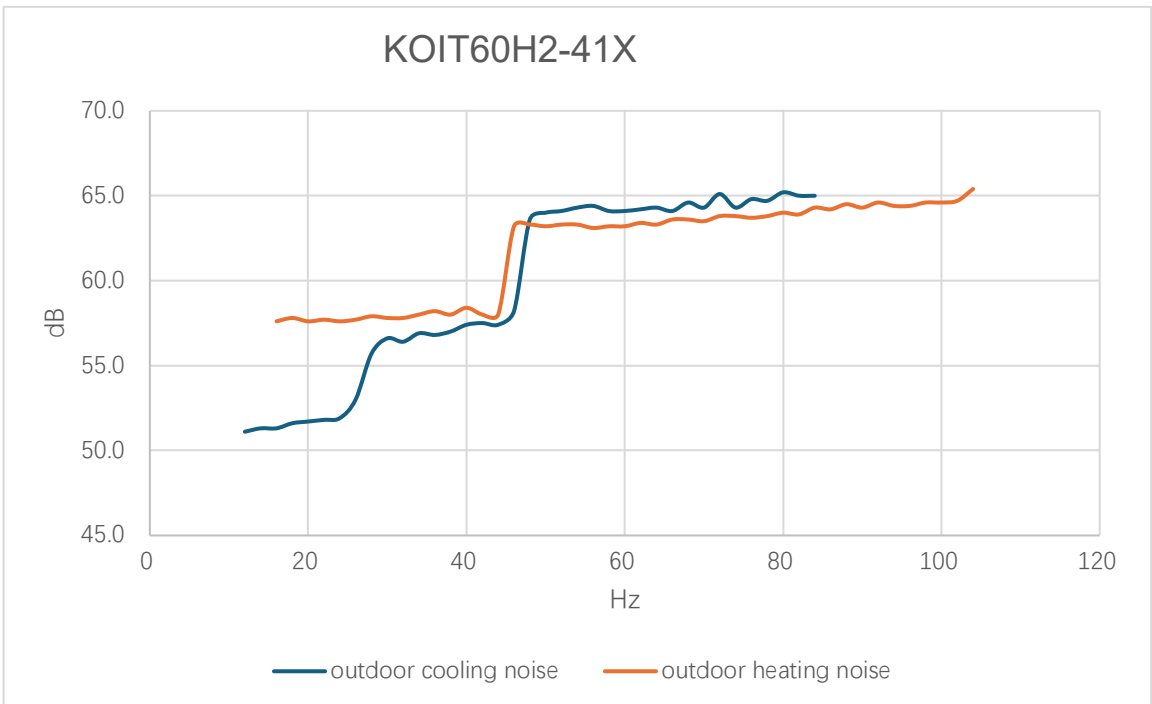
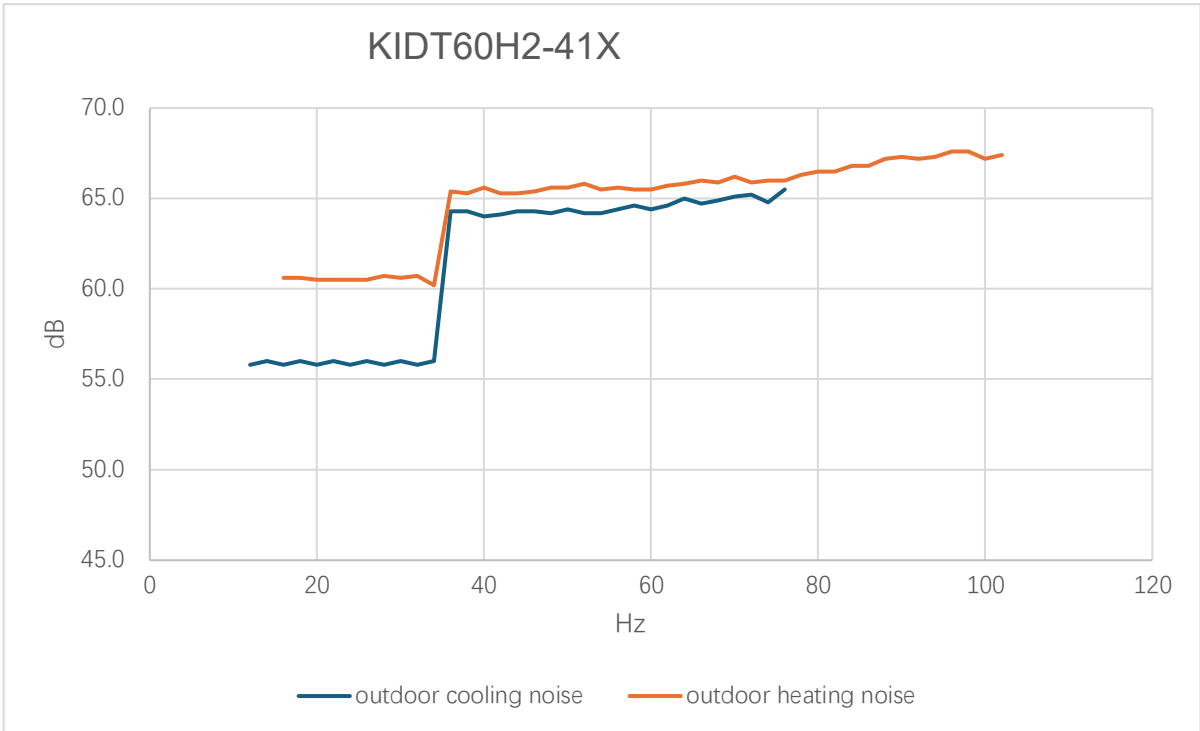

2. Installation manual

2.1 Installation preparation

2.1.1 Notice on Installation

Important Considerations

1. The air conditioner must be installed by professional personnel and the Installation manual is specially used for the professional technician. The installation specifications should be subject to our after-sale service regulations.
2. When filling the combustible refrigerant, any of your rude operations may cause serious injury or injuries to human body and objects.
3. A leak test must be done after the installation completed.
4. It is a must to do the safety inspection before maintaining or repairing an air conditioner using combustible refrigerant in order to ensure that the fire risk is reduced to minimum.
5. It is necessary to operate the machine under a controlled procedure in order to ensure that any risk arising from the combustible gas or vapor during the operation is reduced to minimum.
6. Requirements for the total weight of filled refrigerant and the area of a room to be equipped with an air conditioner (shown in the following tables)

The maximum charge and the required minimum floor area

$$m_1 = (6m^3) \times LFL, m_2 = (52 m^3) \times LFL, m_3 = (260^3) \times LFL$$

$$m_1 = (212 ft^3) \times LFL, m_2 = (1836 ft^3) \times LFL, m_3 = (9,182 ft^3) \times LFL$$

Where LFL is the lower flammable limit in kg/ m³, **R454B** LFL is **0.296kg/ m³**

Where LFL is the lower flammable limit in lb / ft³, **R454B** LFL is **0.0185 lb / ft³**

For the appliances with a charge amount $m_1 < M = m_2$:

The maximum charge in a room shall be in accordance with the following:

$$m_{max} = 0.5 \times LFL \times 2.2 \times A$$

The required minimum floor area A_{min} to install an appliance with refrigerant charge M (kg) shall be in accordance with following:

$$q_{min} = 30 \times m_c / LFL$$

Refrigerant Charge and Room Area Limitations

In UL/CSA60335-2-40, R454B refrigerant is classified as class A2L, which is mildly flammable.

Therefore, R454B refrigerant is suitable for systems needing additional refrigerant charge and which will limit the area of the rooms being served by the system. Similarly, the total amount of refrigerant in the system shall be less than or equal to the allowable maximum refrigerant charge. The allowable maximum refrigerant charge depends on the area of the rooms being served by the system.

NOTE

The nouns in this section are explained as follows:

Mc: The actual refrigerant charge in the system.

A: the actual room area where the appliance is installed.

A_{min}: The required minimum room area.

M_{max}: The allowable maximum refrigerant charge in a room.

Q_{min} : The minimum circulation airflow.

Anv_{min} : The minimum opening area for connected rooms.

TA_{min} : The total area of the conditioned space (For appliances serving one or more rooms with an air duct system).

TA : The total area of the conditioned space connected by air ducts.

1. The room area calculation requirements

CAUTION

The space considered shall be any space which contains refrigerant-containing parts or into which refrigerant could be released. The room area (A) of the smallest, enclosed. Occupied space shall be used in the determination of the refrigerant quantity limits.

For determination of room area (A) when used to calculate the refrigerant charge limit, the following shall apply.

The room area (A) shall be defined as the room area enclosed by the projection to the base of the walls, partitions and doors of the space in which the appliance is installed.

Spaces connected by only drop ceilings, ductwork, or similar connections shall not be considered a single space.

Units mounted higher than 70-55/64 inches and spaces divided by partition walls that are no higher than 62-63/64 inches shall be considered a single space.

Rooms on the same floor and connected by an open passageway between the spaces can be considered a single room when determining compliance to A_{min} , if the passageway complies with all of the following.

- 1) It is a permanent opening.
- 2) It extends to the floor.
- 3) It is intended for people to walk through.

The area of the connected rooms, on the same floor, connected by permanent opening in the walls and/or doors between occupied spaces, including gaps between the wall and the floor. Can be considered a single room when determining compliance to A_{min} , provided all of the following conditions are met as Fig.2-1.

1) Low level opening

- ① The opening shall not be less than Anv_{min} in Table2-1.
- ② The area of any openings above 11-13/16 inches from the floor shall not be considered in determining compliance with Anv_{min} .
- ③ At least 50% of the opening area of Anv_{min} shall be below 7-7/8 inches from the floor.
- ④ The bottom of the opening is not more than 3-15/16 inches from the floor.
- ⑤ The opening is a permanent opening that cannot be closed.
- ⑥ For openings extending to the floor the height shall not be less than 25/32 inches above the surface of the floor covering.

2) High level opening

- ① The opening shall not be less than 50% of Anv_{min} in Table2-1.
- ② The opening is a permanent opening that cannot be closed.
- ③ The opening shall be at least 59 inches above the floor.
- ④ The height of the opening is not less than 25/32 inches.

3) Room size requirement

① The room into which refrigerant can leak, plus the connected adjacent room(s) shall have a total area not less than A_{min} . A_{min} is shown in Table2-3.

② The room area in which the unit is installed shall be not less than 20% A_{min} . A_{min} is shown in Table2-3.

NOTE

The requirement for the second opening can be met by drop ceilings, ventilation ducts, or similar arrangements that provide an airflow path between the connected rooms.

The minimum opening for natural ventilation (A_{nvmin}) in connected rooms is related to the room area (A), the actual refrigerant charge in the system (M_c), and the allowable maximum refrigerant charge in the system (M_{max}).

A_{nvmin} can be determined according to Table 2-1.

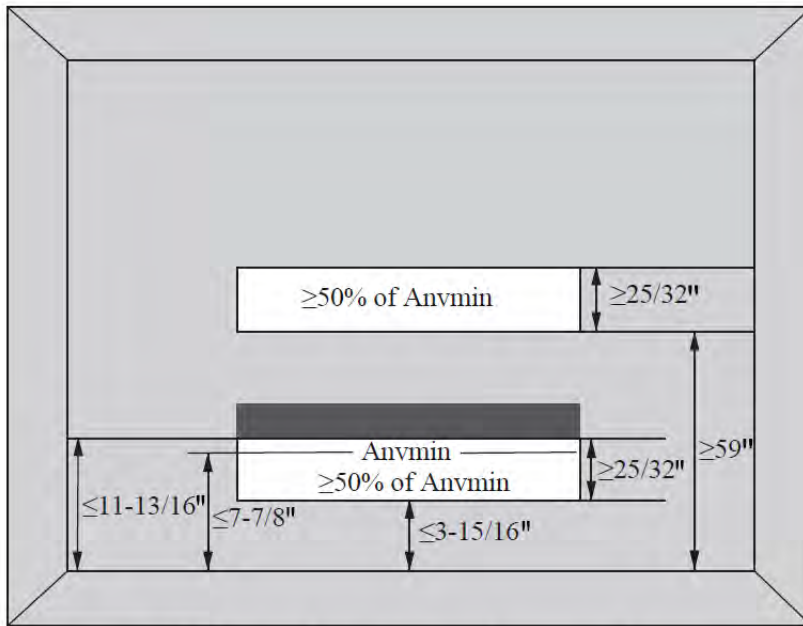

The minimum opening area for connected rooms

Table 2-1

A(ft ²)	M_c (□lbs□oz)		M_{max} (□lbs□oz)		A_{nvmin} (ft ²)
	lbs	oz	lbs	oz	
40	9	9	2	10	0.9
50	9	9	3	5	0.8
60	9	9	4	0	0.7
70	9	9	4	10	0.6
80	9	9	5	5	0.6
90	9	9	6	0	0.5
100	9	9	6	10	0.4
110	9	9	7	5	0.3
120	9	9	8	0	0.2
130	9	9	8	10	0.2
140	9	9	9	5	0.1

150	9	9	10	0	0.0
160	9	9	10	10	0.0

Note: Take the Mc=9 lbs 9 oz as an example.

For appliances serving one or more rooms with an air duct system, the room area calculation shall be determined based on the total area of the conditioned space (TA) connected by ducts taking into consideration that the circulating airflow distributed to all the rooms by the appliance integral indoor fan will mix and dilute the leaking refrigerant before entering any room.

2. The allowed maximum refrigerant charge and required minimum room area

If the fan incorporated to an appliance is continuously operated or operation is initiated by a REFRIGERANT DETECTION SYSTEM with a sufficient CIRCULATION AIRFLOW rate, the allowable maximum refrigerant charge (M_{max}) and the required minimum room area (A_{min}/TA_{min}) is shown in Table 2-2 and Table 2-3.

The allowable maximum refrigerant charge

Table 2-2

A/TA(ft ²)	Mmax(□lbs□oz)		A/TA(ft ²)	Mmax(□lbs□oz)	
	lbs	oz		lbs	oz
40	2	10	160	10	10
50	3	5	170	11	5
60	4	0	180	12	0
70	4	10	190	12	10
80	5	5	200	13	5
90	6	0	210	14	0
100	6	10	220	14	10
110	7	5	230	15	5
120	8	0	240	16	0
130	8	10	250	16	10
140	9	5	260	17	5
150	10	0			

The required minimum room area

Table 2-3

Mc(□lbs□oz)		Amin/Tamin(ft ²)	Mc(□lbs□oz)		Amin/Tamin(ft ²)
lbs	oz		lbs	oz	
4	6	66.1	11	0	165.3
4	13	72.7	11	7	171.9
5	4	79.3	11	14	178.5
5	11	86.0	12	5	185.1
6	2	92.6	12	12	191.7
6	9	99.2	13	3	198.4
7	0	105.8	13	10	205.0
7	7	112.4	14	1	211.6
7	15	119.0	14	8	218.2

8	6	125.6	14	15	224.8
8	13	132.2	15	6	231.4
9	4	138.8	15	14	238.0
9	11	145.5	16	5	244.6
10	2	152.1	16	12	251.2
10	9	158.7	17	3	257.9

The minimum circulation airflow

Table 2-4

Mc(□lbs□oz)		Qmin(CFM)	Mc(□lbs□oz)		Qmin(CFM)
lbs	oz		lbs	oz	
4	6	119	11	0	298
4	13	131	11	7	310
5	4	143	11	14	322
5	11	155	12	5	334
6	2	167	12	12	346
6	9	179	13	3	358
7	0	191	13	10	370
7	7	203	14	1	382
7	u	215	14	8	394
8	6	227	14	15	405
8	13	239	15	6	418
9	4	251	15	14	430
9	11	263	16	5	442
10	2	275	16	12	454
10	9	287	17	3	466

CAUTION

The allowable maximum refrigerant charge of the Table 2-2 or the required minimum room area of the Table 2-3 is available only if the following conditions are met:

Minimum velocity of 3.28ft/s, which is calculated as the indoor unit airflow divided by the nominal face area of the outlet. And the grill area shall not be deducted.

Minimum airflow rate must meet the corresponding values in Table 2-4, which is related to the actual refrigerant charge of the system (Mc).

R454B refrigerant leakage sensor is configured.

NOTE

The maximum refrigerant limit described above applies to unventilated areas. If adding additional measures, such as areas with mechanical ventilation or natural ventilation, the maximum refrigerant charge can be increased or the minimum room area can be reduced.

R454B refrigerant leakage sensor is configured for the indoor unit, meets the incorporated circulation airflow requirements, the maximum refrigerant charge or minimum room area can be determined according to Table 2-2 or Table 2-3.

CAUTION

If the actual room area, air outlet height, and refrigerant charge amount are not reflected in the above table. more severe cases need to be considered according to the data in the table 2-1, 2-2, 2-3, 2-4.

1. Site Safety



Open Flames Prohibited



2. operation safety



Mind Static Electricity



Must wear protective clothing and anti-static gloves



Don't use mobile phone

3. Installation Safety

Refrigerant Leak Detector

Appropriate Installation Location





















The left picture is the schematic diagram of a refrigerant leak detector.

Please note that:

1. The installation site should be well-ventilated.
2. The sites for installing and maintaining an air conditioner using Refrigerant R454B should be free from open fire or welding, smoking, drying oven or any other heat source higher than 396°C - 745°F which easily produces open fire.
3. When installing an air conditioner, it is necessary to take appropriate anti-static measures such as wear anti-static clothing and/or gloves.
4. It is necessary to choose the site convenient for installation or maintenance wherein the air inlets and outlets of the indoor and outdoor units should be not surrounded by obstacles or close to any heat source or combustible and/or explosive environment.
5. If the indoor unit suffers refrigerant leak during the installation, it is necessary to immediately turn off the valve of the outdoor unit and all the personnel should go out till the refrigerant leaks completely for 15 minutes. If the product is damaged, it is a must to carry such damaged product back to the maintenance station and it is prohibited to weld the refrigerant pipe or conduct other operations on the user's site.
6. It is necessary to choose the place where the inlet and outlet air of the indoor unit is even.
7. It is necessary to avoid the places where there are other electrical products, power switch plugs and sockets, kitchen cabinet, bed, sofa and other valuables right under the lines on two sides of the indoor unit.

Suggested Tools

Tool	Picture	Tool	Picture	Tool	Picture
Standard Wrench		Pipe Cutter		Vacuum Pump	
Adjustable/ Crescent Wrench		Screw drivers (Phillips & Flat blade)		Safety Glasses	
Torque Wrench		Manifold and Gauges		Anti-static Gloves	
Hex Keys or Allen Wrenches		Level		Refrigerant Scale	
Drill & Drill Bits		Flaring tool		Micron Gauge	
Hole Saw		Clamp on Amp Meter		Welding Gun	

Dedicated Distribution Device and Wire for Air Conditioner

Min. Circuit Ampacity of Air Conditioner (A)	Minimum Wire Cross- sectional Area(mm ²)	Specification of Socket or Switch(A)	Fuse Specification(A)
≤8	0.75	15	15
>8 and ≤10	1.0	15	15
>10 and ≤15	1.5	20	25
>15 and ≤24	2.5	25	40
>24 and ≤28	4.0	35	45
>28 and ≤32	6.0	40	55

NOTE

The table above for reference only, the installation shall meet the requirements of local laws and regulations.

2.1.2 Unit dimension

2.1.2.1 Indoor unit dimension

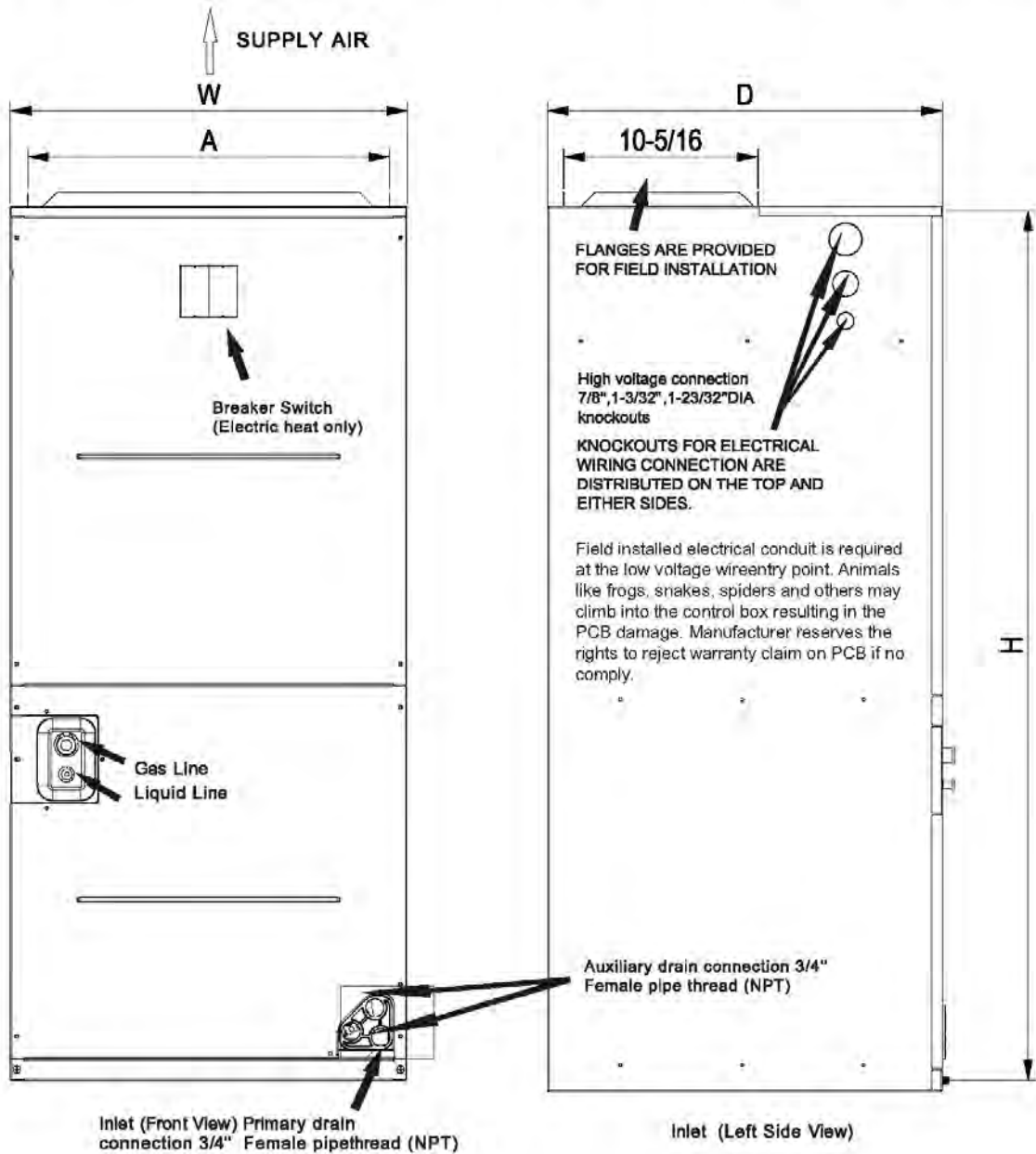

Unit dimensions

Model	Dimensions (in.)					
	H	W	D	A	Liquid Line Connection	Gas Line Connection
KIDT24H2-41X KIDT36H2-41X	46-1/2	21	21	19-1/4	3/8	3/4
KIDT48H2-41X KIDT60H2-41X	56	24-1/2	21	22-3/4	3/8	7/8

2.1.2.2 Outdoor unit dimension

Two models sharing the same chassis are suit for most residential air conditioner and heat pump applications. When mounting the condensing unit on a roof or pad, be sure its dimension no less than 29" x 29".

Table 4-1 Condensing unit dimensions

Unit Dimensions	
Model	H×W×D(Inches)
KIDT24H2-41X	24-15/16×29-1/8×29-1/8
KIDT36H2-41X	24-15/16×29-1/8×29-1/8
KIDT48H2-41X	33-3/16×29-1/8×29-1/8
KIDT60H2-41X	33-3/16×29-1/8×29-1/8

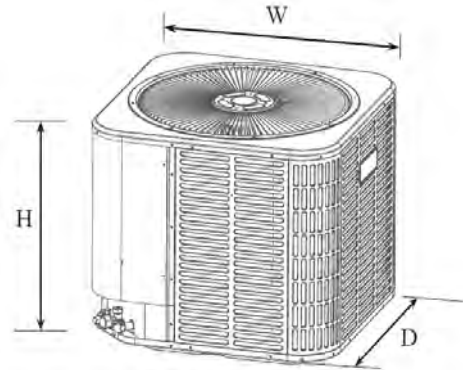

2.1.3 Diagram of unit installation space

2.1.3.1 Diagram of installation space and location for outdoor unit

Installation Clearance Requirement

Ensure the top discharge area is unrestricted for at least 60 inches above the unit.

Do not locate condensing unit near bedrooms because normal operational sounds may be annoying. Position unit to allow adequate space for unobstructed airflow, wiring, refrigerant pipes, and serviceability.

Allow a minimum of 12 in. clearance on one side of access panel to a wall and a minimum of 24 in. on the adjacent side of access panel. Maintain a distance of 24 in. between units.

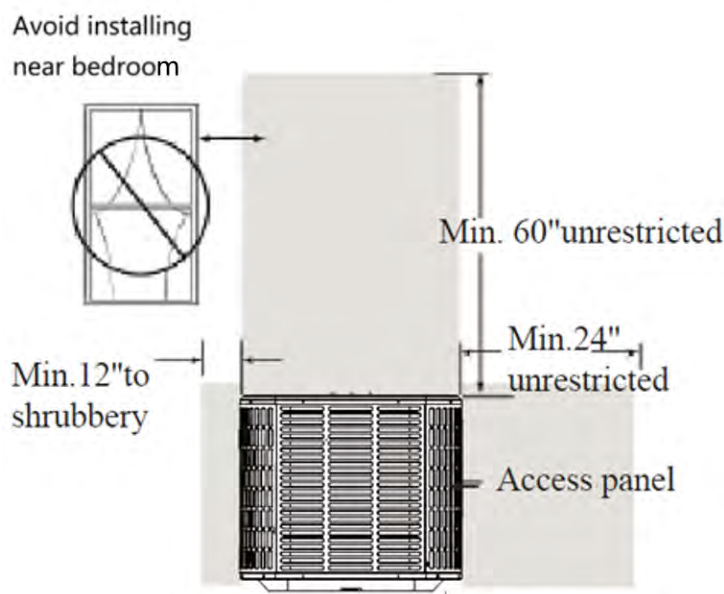

Do not choose the installation location on the roof to avoid rain, ice and snow falling directly on the top of the unit.

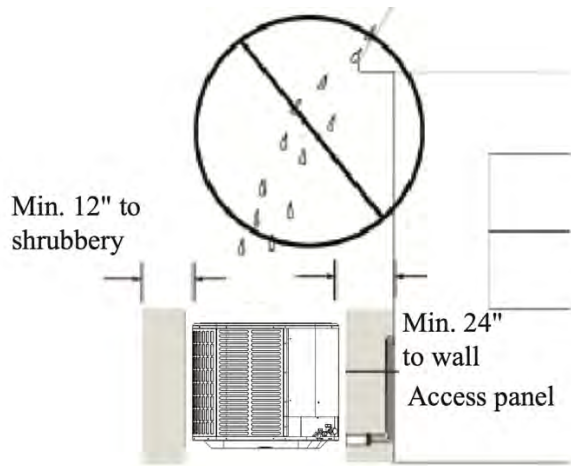

2.1.3.2 Diagram of installation location and space for indoor unit

a) Horizontal position

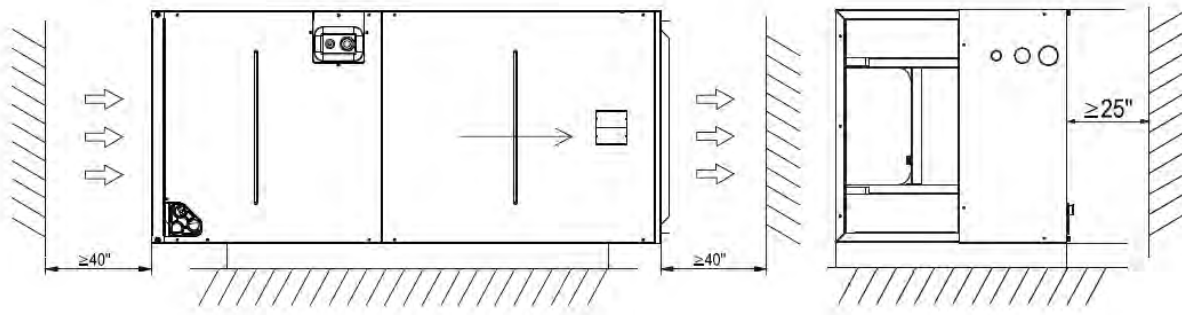

b) Vertical position
Clearance requirement

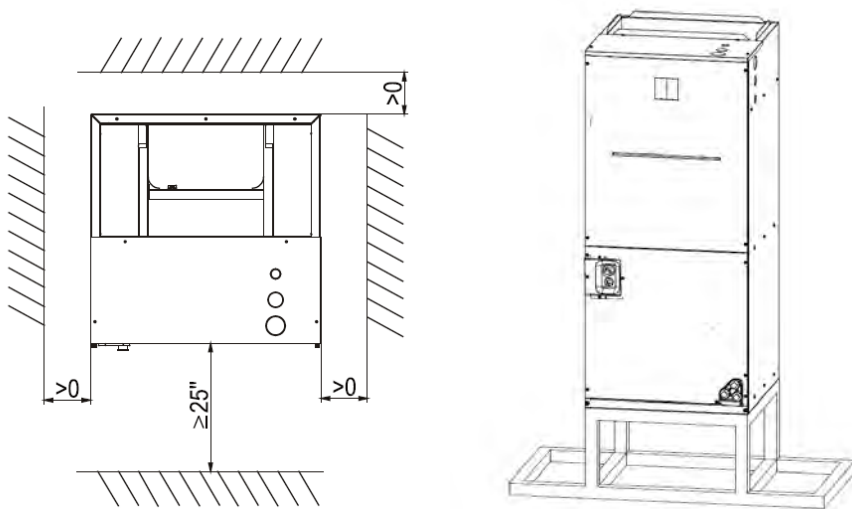

2.2 Unit installation

2.2.1 Indoor unit installation

Vertical up-flow and horizontal right-slow configurations are factory settings on all models. If return air is to be ducted, install duct flush with floor. Use fireproof resilient gasket 1/8" to 1/4" thick between the ducts, unit and floor. Set unit on floor over opening.

IMPORTANT

Lightly tighten the drain connections so they do not leak.

Using excessive force may cause damage to the drain connections. Torque applied to drain connections should NOT exceed 10.ft.lbs.

Dimension from unit front below

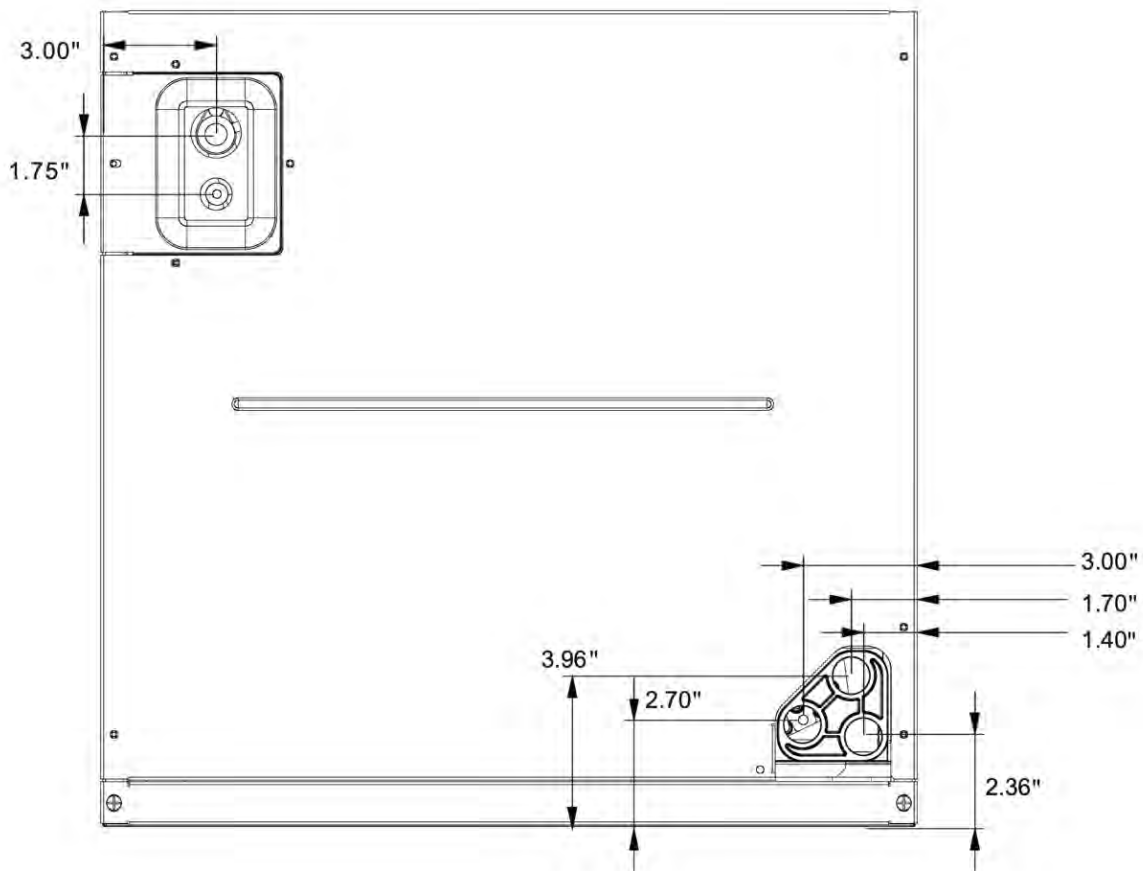

NOTE

The unit can be installed in a Vertical (Down and Up) and Horizontal (Right and Left) configuration shown as following.

Vertical installation

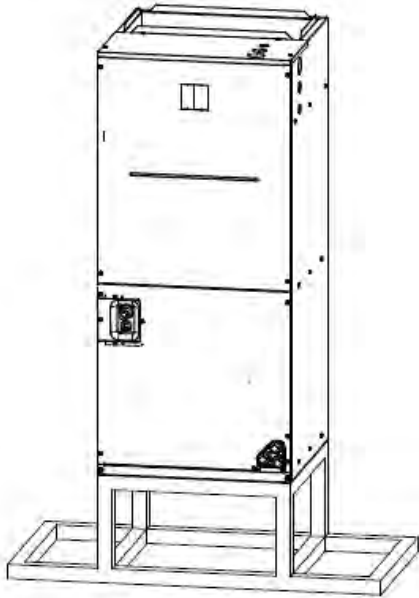

Horizontal installation

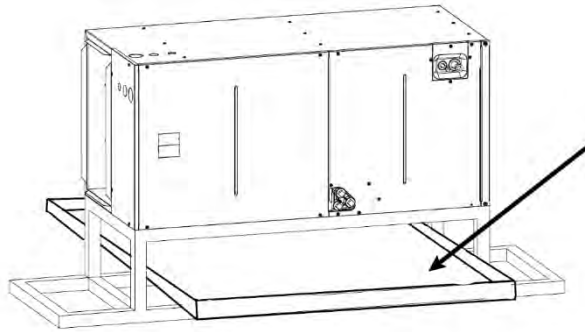

Note: For horizontal installation, a secondary drain pan (not supplied) is suggested to install under the unit to prevent water leakage.

Please follow these steps to perform Vertical up installation and Horizontal right installation:

1. Open the upper cover.
2. Open the cover of the electronic control box.
3. Connect the wire according to the wiring diagram.
4. Connect the pipes.
5. Install the drainage pipes.

The unit installed as Upflow, Downflow, Horizontal Left and Horizontal Right orientations.

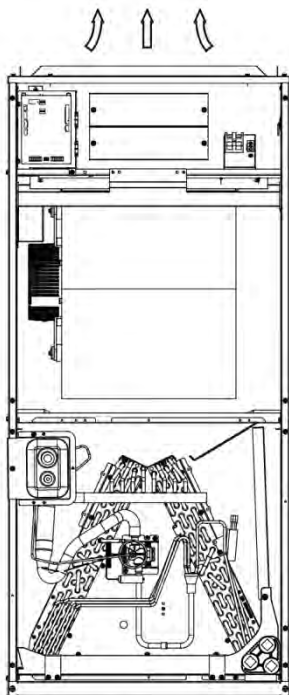

Upflow

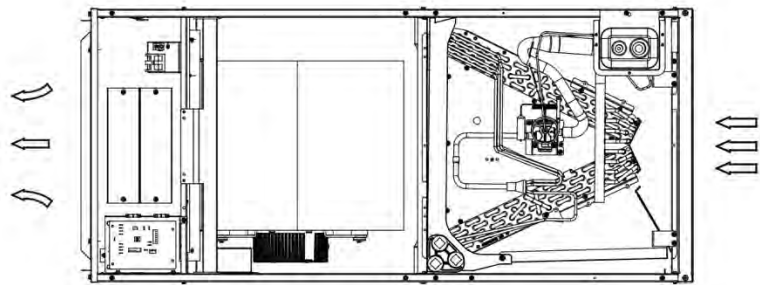

horizontal left

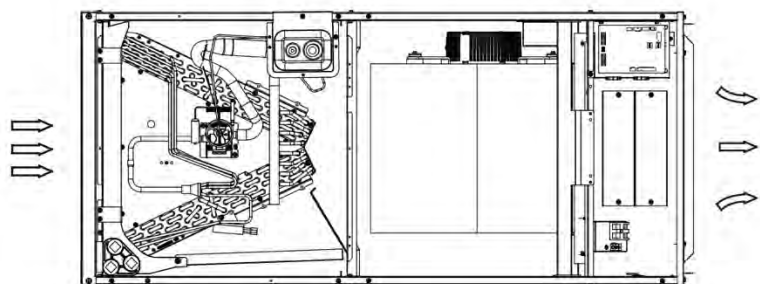

horizontal right

NOTE

For the downward air outlet installation, you need to purchase service parts from the dealer and have a qualified personnel to install them.

Indication of the position of each temperature sensor on the evaporator:

KIDT24H2-41X | KIDT36H2-41X

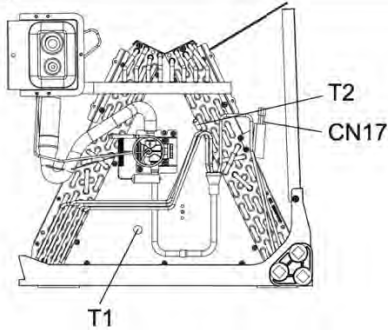

KIDT48H2-41X | KIDT60H2-41X

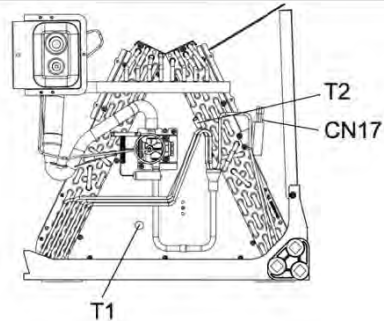

INSTRUCTION

For the horizontal installation (Left), how to disassemble and reinstall the evaporator assembly.

- 1. Remove the fixed plate of the filter, then take the filter off.
- 2. Remove the upper cover assembly.

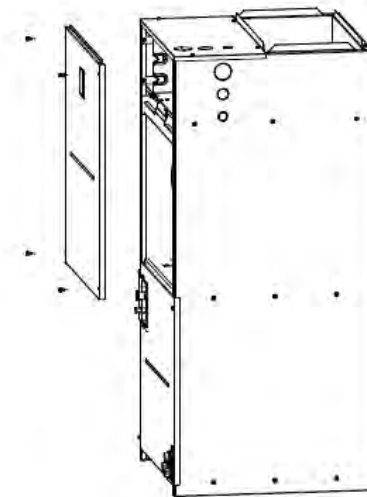
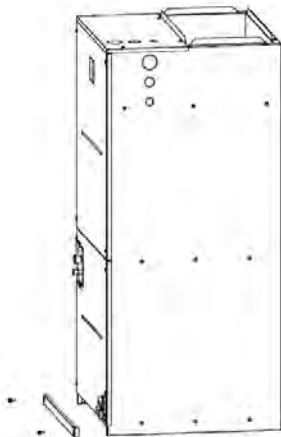

- 3. Remove evaporator cover plate.

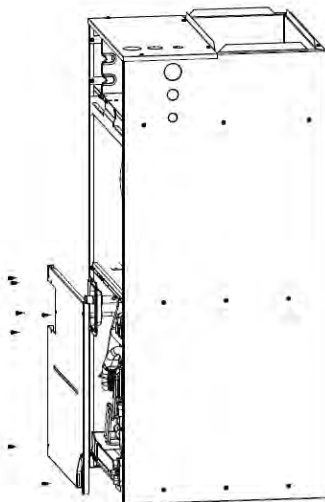

- 4. Remove the plug of the CN17 refrigerant sensor and the plug of the CN18 temperature sensing bag.

CN17: Refrigerant Sensor
CN18: Temperature Sensor

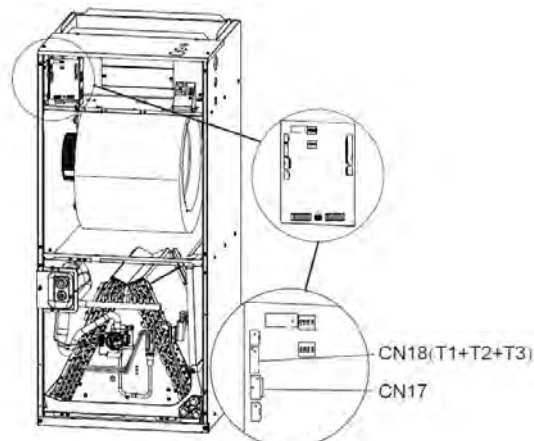

5. Remove CN17、CN18 wire ties.

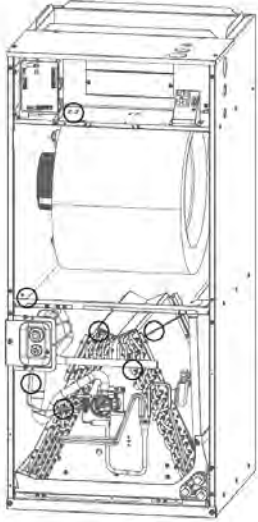

6. Take out the evaporator and drain pan and rotate 180°.

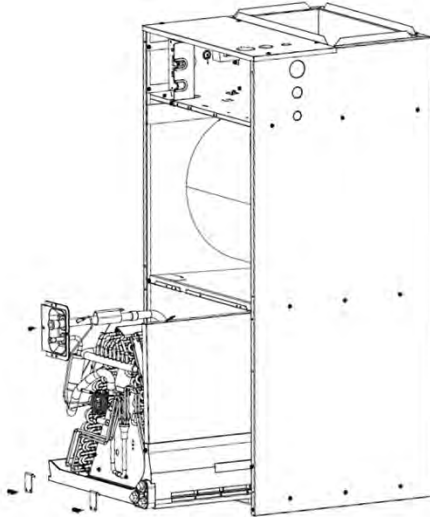

7. Reinstall the evaporator.

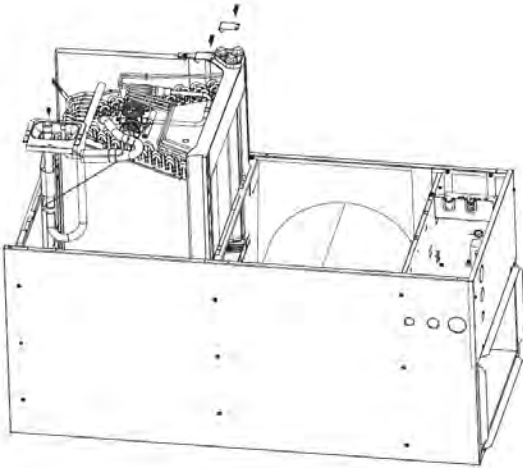

8. Reinstall CN17 and CN18 plug and tie up the sensor wires.

NOTICE

The wire body needs to pass through the wire groove from the water receiving tray and be stuck on the hook of the water receiving tray.

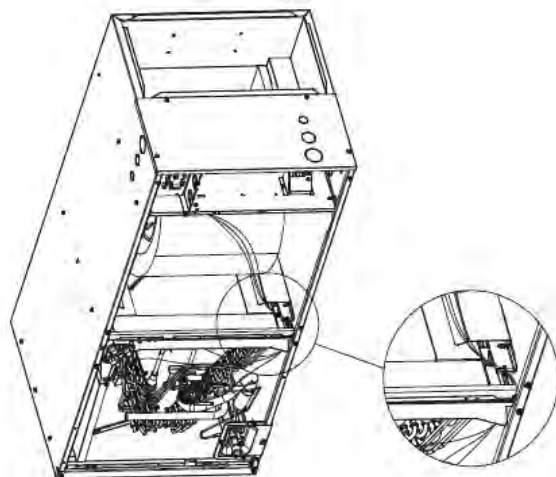
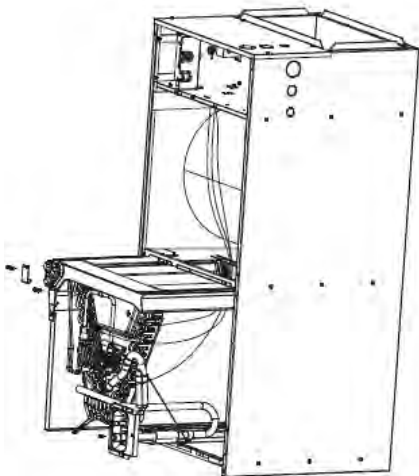

9. Reinstall the drain pan fixed plate and auxiliary support plate.

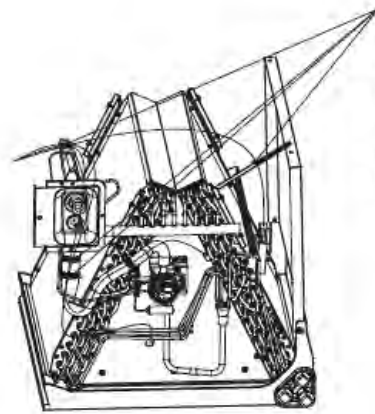
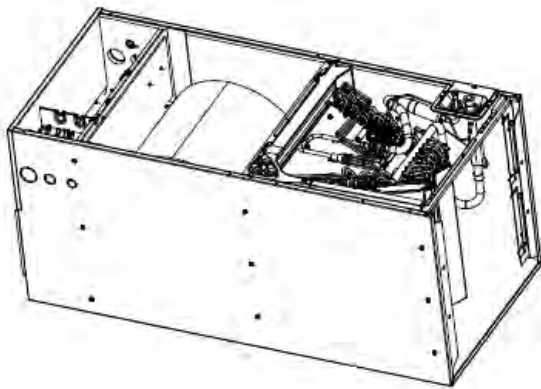

Use cable ties to bind and fix the environmental temperature sensitive bag as shown in the figure.

10. Reinstall evaporator cover plate.

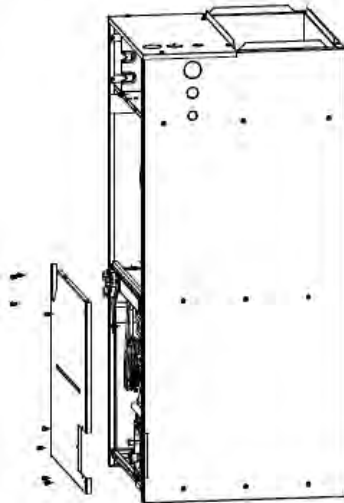

11. Reinstall the upper cover assembly.

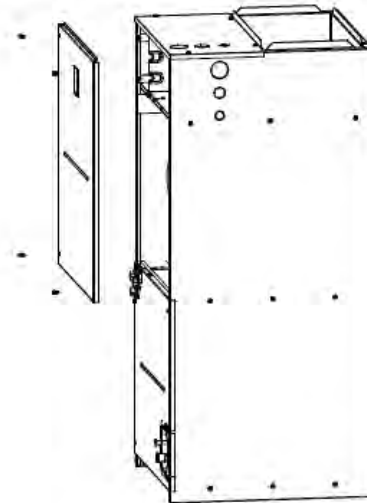

12 Reinstall the filter and filter plate.

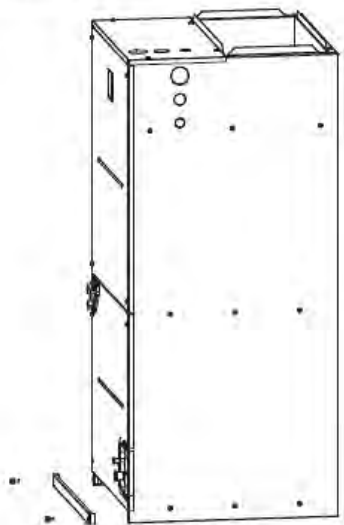

13. Connect the wire according to the wiring diagram.

2.2.2 Outdoor unit installation

Exposure to a corrosive environment may shorten the life of the equipment, corrode metal parts, and/or negatively affect unit performance. Corrosive elements include, but are not limited to: sodium chloride, sodium hydroxide, sodium sulfate, and other compounds commonly found in ocean water, sulfur, chlorine, fluorine, fertilizers, and various chemical contaminants from industry/manufacturing plants. If installed in areas which may be exposed to corrosive environments, special attention should be given to the equipment placement and maintenance.

- Lawn sprinklers/waste water should not spray directly on the unit cabinet for prolonged periods.
- In coastal areas: locate the unit on the side of the building away from water.

Cold Climate Considerations

Precautions must be taken for units being installed in areas where snow accumulation and prolonged below-freezing temperatures occur. Elevate unit as per local climate and code requirements. This additional height will allow drainage of snow and ice melted during defrost cycle to flow out smoothly prior to its refreezing. A snow drift barrier should be installed around the unit to prevent a build-up of snow on the unit sides.

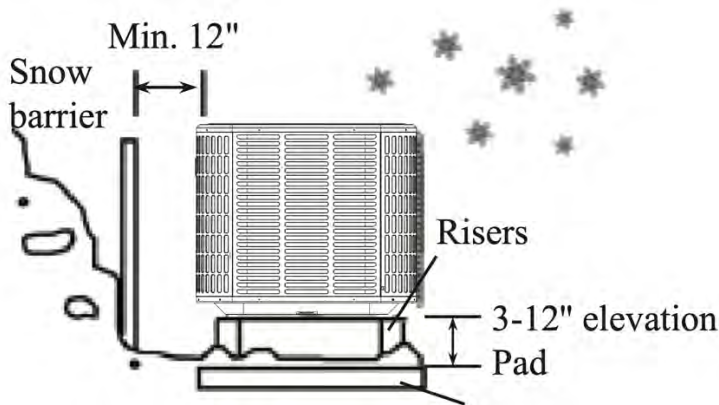

Consideration to prevent refreezing

When mounting the unit on a roof, be sure the roof will support the unit's weight obtained from nameplate.

Properly selected isolation is recommended to prevent sound or vibration transmission to the building structure.

2.2.3 Piping connection

2.2.3.1 Notice and requirement for piping connection

Refrigerant pipe Limits

Use only the pipe size indicated in below table and determine required pipe length. If the suction pipe set is greater than 50 feet, do not use a larger suction pipe than recommended.

The pipe sizes and maximum length

Capacity Model	Liquid Line	Suction Line	Total Equivalent Length (ft)				
			25	50	75	100	164
	Dimensions in inches		Maximum Elevation Difference (ft)				
KOIT24H2-41G	3/8 Std.	3/4 Std.	25	50	45	40	/
KOIT36H2-41G	3/8 Std.	3/4 Std.	25	50	50	40	/
KOIT48H2-41G	3/8 Std.	7/8 Std.	25	50	50	40	35
KOIT60H2-41G	3/8 Std.	7/8 Std.	25	50	50	40	35

Std.: Standard pipe size.

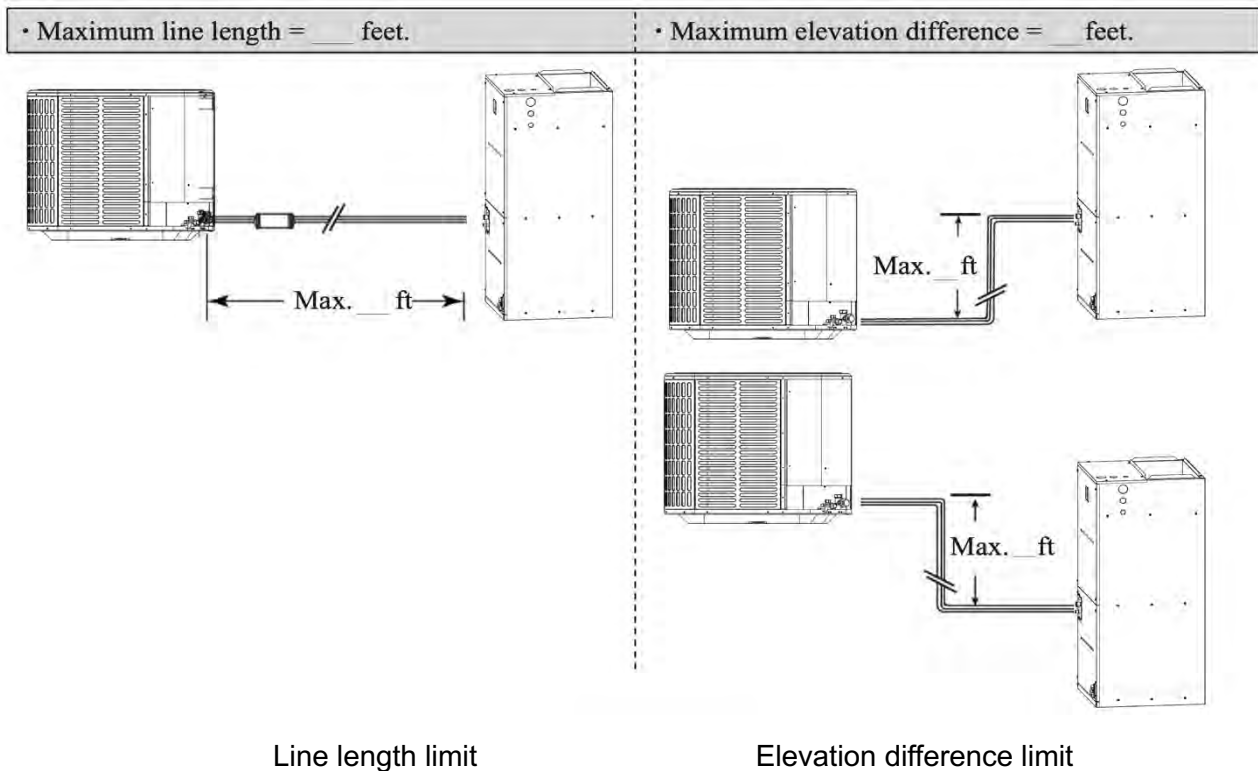

NOTE

The suction pipe must always be insulated.

DO NOT allow the suction pipe and liquid pipe contact directly (metal to metal).

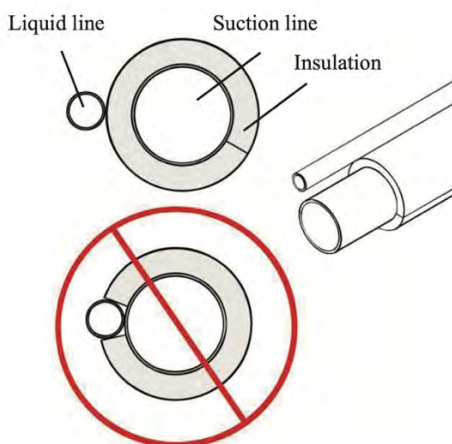

Use the existing Refrigerant pipes

CAUTION

If using the existing refrigerant lines, make sure that all joints are brazed, not soldered.

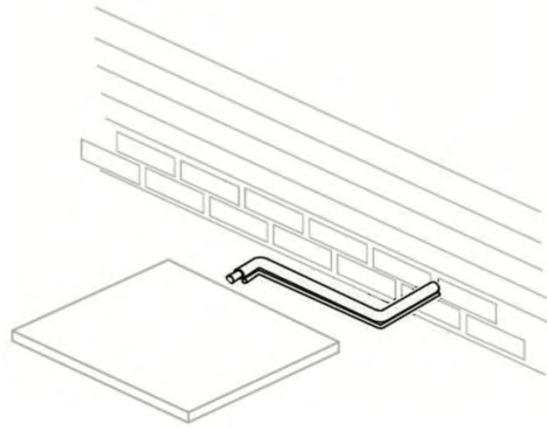

The existing refrigerant lines

IMPORTANT

The manufacturer recommends installing only approved matched indoor and outdoor systems. All of the manufacturer's split systems are AHRI rated with TXV indoor units. Some of the benefits of installing approved matched indoor and outdoor split systems are maximum efficiency, optimum performance and the best overall system reliability.

Refrigerant pipes ROUTING

Comply with National, State, and Local Codes when isolating pipe sets from joists, rafters, walls, or other structural elements. Take precautions to prevent noise within the building structure due to vibration transmission from the refrigerant pipes.

For Example:

- Use isolation type hangers when the refrigerant pipes have to be fastened to floor joists or other framing.
- Isolation hangers should also be used when refrigerant pipes traverse stud spaces or enclosed ceilings.
- Where the refrigerant pipes pass through a wall or sill, it should be insulated and isolated.
- Isolate the pipes from all ductwork.
- Minimize the number of 90° turns.

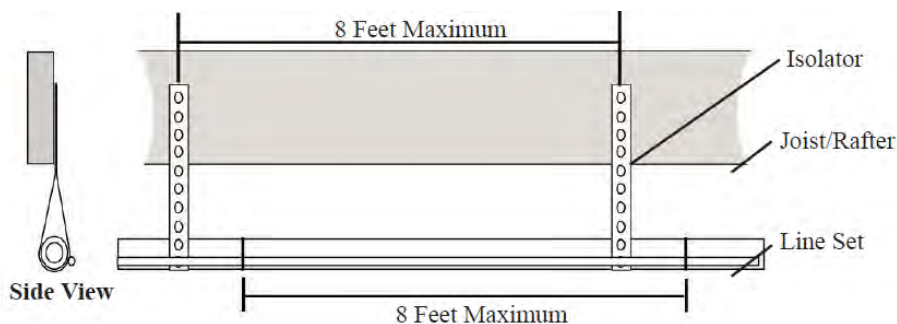

Secure suction pipe from joists using isolators every 8 ft. secure liquid pipe directly to insulated suction pipe using tape, wire, or other appropriate method every 8 ft.

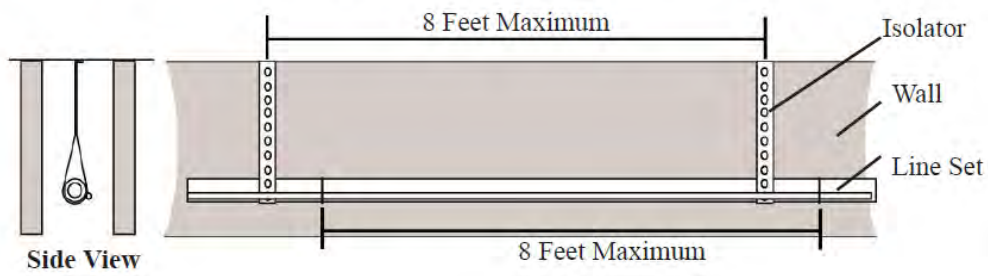

Secure suction pipe using isolators every 8 ft. secure liquid pipe directly to insulated suction pipe using tape, wire, or other appropriate method every 8 ft.

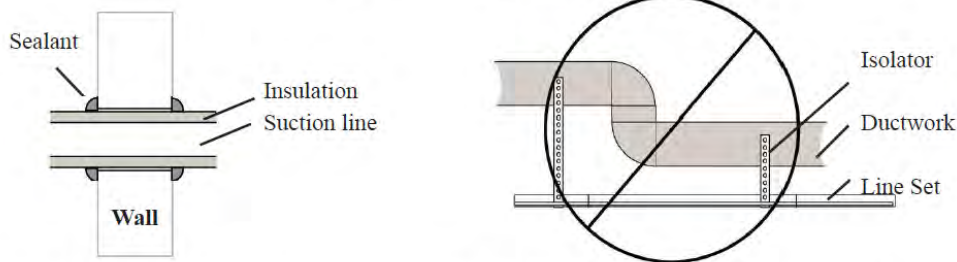

Leak check and evacuation must be done before opening the service valves.
The gas service valve must be opened BEFORE opening the Liquid Service Valve!

1. Remove service valve cap.
 2. Fully insert hex wrench into the stem and counterclockwise until valve stem just touches the rolled edge (approximately five turns.)
 3. Replace and tighten the valve stem cap to prevent leaks. Additional 1/6turn may be required.
- Repeat 1 to 3 for Liquid Service Valve.

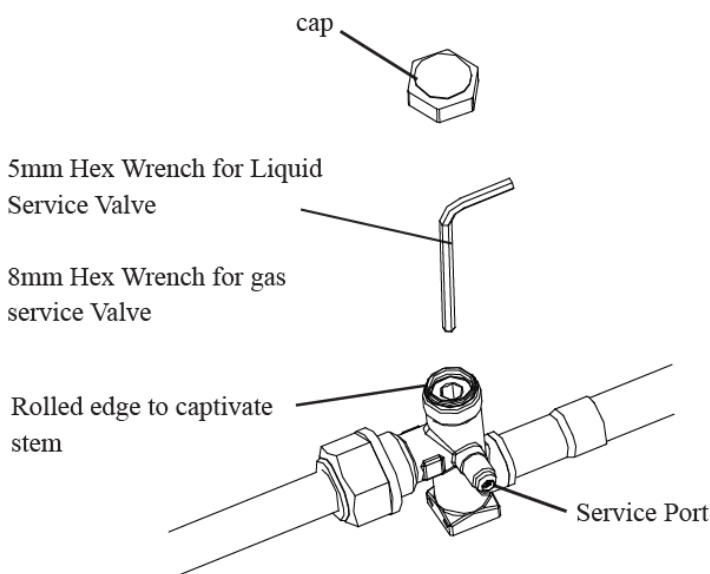

! WARNING

Extreme caution should be exercised when opening the Liquid Service Valve. Turn counterclockwise until the valve stem just touches the rolled edge. No torque is required. Failure to follow this will result in abrupt release of system charge and may lead to personal injury and /or property damage.

2.2.3.2 Pipe flaring

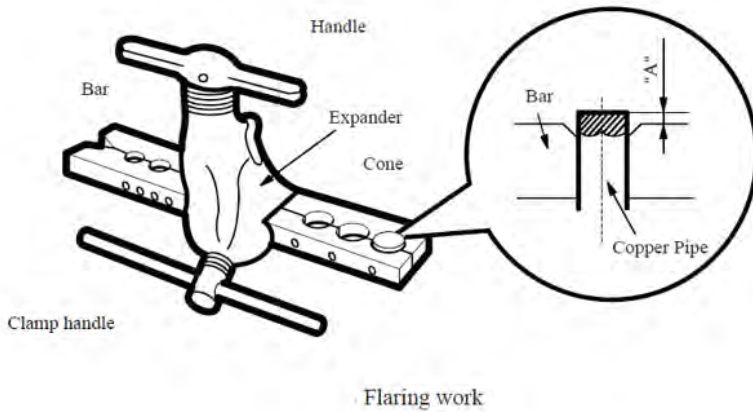

Main cause for gas leakage is due to defect in pipe flaring. Carry out correct flaring work in the following procedure.

A. Cut the pipes and the cable.

- 1) Use the piping kit accessory or the pipes purchased locally.
- 2) Measure the distance between the indoor and the outdoor unit.
- 3) Cut the pipes a little longer than measured distance.
- 4) Cut the cable 1.5m longer than the pipe length.

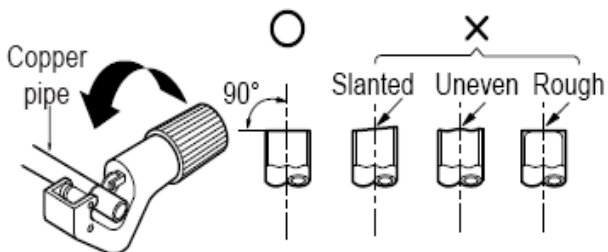

B. Burrs removal

- 1) Completely remove all burrs from the cut cross section of pipe/tube.
- 2) Put the end of the copper tube/pipe in a downward direction as you remove burrs in order to avoid dropping burrs into the tubing.

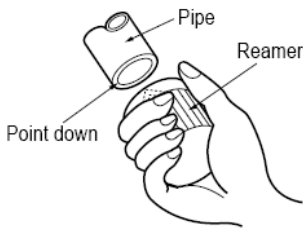

C. Flaring work

- Carry out flaring work using flaring tool as shown below.

Outside diameter	A
Inch	Inch
3/8"	0.03"~0.04"
3/4"	0.02"~0.03"
7/8"	0.02"~0.03"

Firmly hold copper pipe in a die in the dimension shown in the table above.

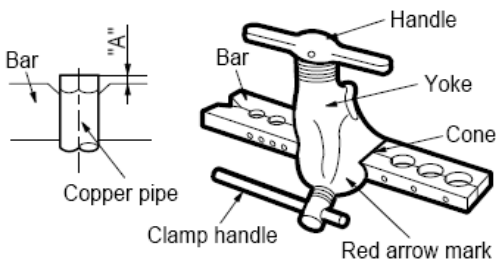

D. Check

- 1) Compare the flared work with figure below.
- 2) If flare is noted to be defective, cut off the flared section and do flaring work again.

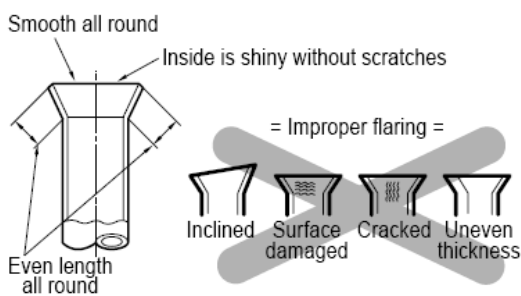

2.2.3.3 Connect pipes of indoor and outdoor units

Pipe Connection

You should first connect the low-pressure pipe, then the high-pressure pipe.

1. Align the center of the two pipes that you will connect.
2. Tighten the flare nut as tightly as possible by hand.
3. Using a wrench, grip the nut on the unit tubing.

NOTE

Use two wrench to connect the pipe with indoor/outdoor pipes to avoid the copper pipe cracking.

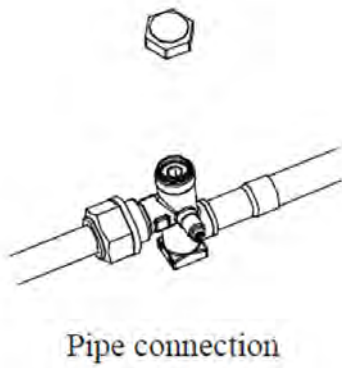

4. While firmly gripping the nut, use a torque wrench to tighten the flare nut according to the torque values.

Torque Values

Connecting Pipe Size	Torque Values (lbf*in)
3/8"	327-372
3/4"	620-664
7/8"	690-735

5. Insert the connecting pipe of the indoor unit into the reamer transfer nozzle flaring of the outdoor unit, and braze the connecting port.

CAUTION

- Ensure to wrap insulation around the piping. Direct contact with the bare piping may result in burns or frostbite.
- Make sure the pipe is properly connected. Over tightening may damage the bell mouth and under tightening may lead to leakage.

6. Insulate all the piping, including the gas valve of the outdoor unit.

7. Open the stop valves of the outdoor unit to start the flow of the refrigerant between the indoor and outdoor unit.

CAUTION

- Check to make sure there is no refrigerant leak after completing the installation work. If there is a refrigerant leak, ventilate the area immediately and evacuate the system (refer to the Air Evacuation section of this manual).

2.2.4 Vacuum and leak detection

2.2.4.1 Vacuum pumping

Do not open the service valves until the leak check and evacuation are complete.

1. Evacuate until the micron gauge reads no higher than 350 microns, then close the valve to the vacuum pump.

2. Evacuation is complete if the micron gauge does not rise above 500 microns in one minute.

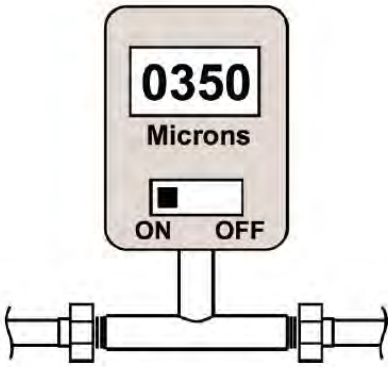

2.2.4.2 Leak detection methods

Leak check is required for the brazed pipe connections.

1. Pressurize the brazed refrigerant pipes and indoor coil to at least 150 PSIG with nitrogen (N₂).
2. Check for leaks by using soapy bubbles at each brazed point.

150PSIG

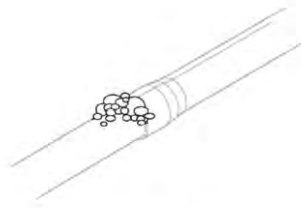

Charge dry nitrogen to the system

Leak check

2.2.5 Refrigerant adding

Refrigerant Charge

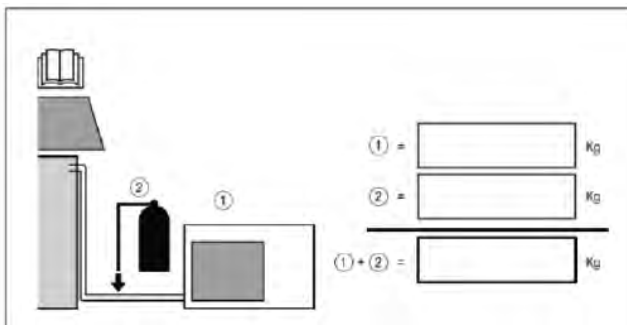

- ①=precharged part(See the nameplate above)
- ②=added during installation(See the manual)
- ①+②= Total Amount

Pipe Length and Additional Refrigerant

Model	KOIT24H2-41X	KOIT48H2-41X	KOIT36H2-41X	KOIT60H2-41X
Length of pipe with standard charge(ft)	25	25	25	25
Refrigerant capacity of standard charge(lbs)	4.74	6.28	8.82	8.82
The longest pipe length(ft)	100	100	165	165
Additional refrigerant charge(lbs/ft)	0.0335	0.0335	0.0335	0.0335
Max.diff. in level between indoor and outdoor unit(ft)	50	50	50	50

For example, for a 36K model, when the pipe is 100ft, the additional refrigerant capacity is $(100-25) \times 0.0335 = 2.51$ lbs, and the refrigerant capacity of the whole model is $6.28 + 2.51 = 8.79$ lbs.

Total Refrigerant Capacity (lb)

Model	Category	LFL(lbs/ft ³)	h0(ft)	Pipe Length(ft)				
				25	49	66	98	164
KOIT24H2-41X	R454B	0.0185	7.2	4.74	5.57	6.12	7.22	/
KOIT36H2-41X				6.28	7.11	7.66	8.76	/
KOIT48H2-41X				8.82	9.65	10.2	11.3	13.5
KOIT60H2-41X				8.82	9.65	10.2	11.3	13.5

Minimum Room Area (ft²)

Model	Category	LFL(lbs/ft ³)	h0(ft)	Pipe Length(ft)				
				25	49	66	98	164
KOIT24H2-41X	R454B	0.0185	7.2	71.0	26.0	28.0	33.0	/
KOIT36H2-41X				95.0	32.0	35.0	40.0	/
KOIT48H2-41X				40.0	44.0	47.0	52.0	62.0
KOIT60H2-41X				40.0	44.0	47.0	52.0	62.0

2.2.6 Installation of drain pipe

2.2.6.1 Indoor side drain pipe

1. When the air handler is installed **vertically**, please block the upper drainage hole with a cover. The lower right of the drainage hole is connected with the drainage pipe(②), and the lower left of the drainage hole is connected with the overflow pipe(①) that should be exposed to the air; If the pipe ① is draining, which means the pipe ② is blocked. Contact maintenance personnel as soon as possible.

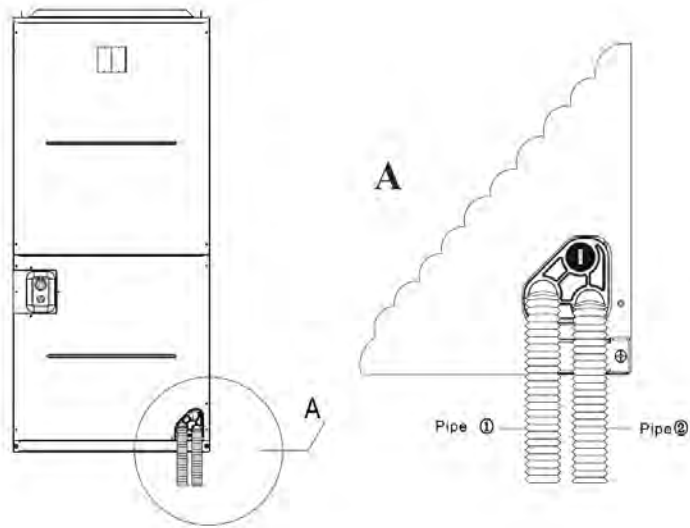

Vertical

2. When installing the air handler **lying down**, the upper drainage hole is covered, the lower left of the drainage hole is connected with the drainage pipe(②), the lower right of the drainage hole is connected with the overflow pipe (①) that should be exposed to the air.
 If the pipe ① is draining, which means the pipe ② is blocked. Contact maintenance personnel as soon as possible.

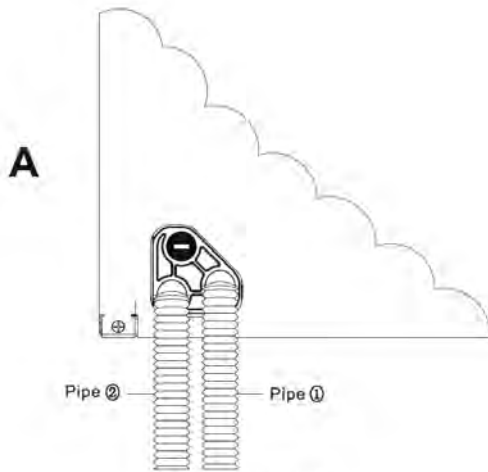
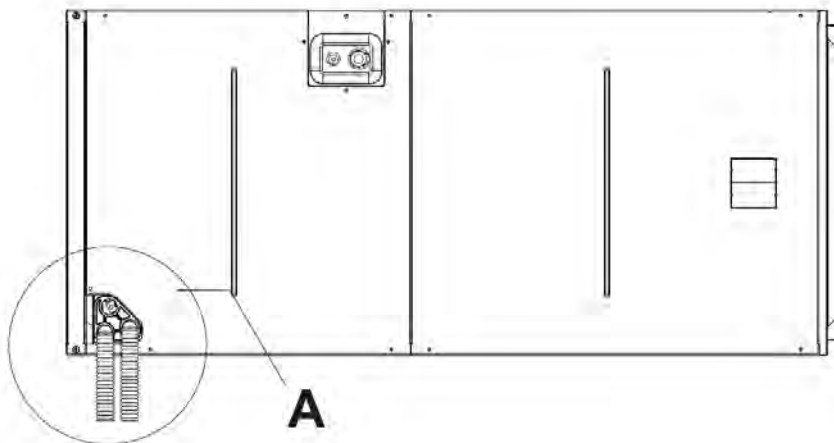

Horizontal right

Installation in an unconditioned space

There are two pairs of coil rails in the air handler for default and counter flow application. If the air handler is installed in an unconditioned space, the two unused coil rails should be removed to minimize air handler surface sweating.

The coil rails can be easily removed by taking off the 6 mounting screws from both sides of the cabinet.

2.2.7 Installation of the duct

2.2.7.1 Dimensions of the supply air outlet / return air inlet

Field ductwork must comply with the National Fire Protection Association NFPA 90A, NFPA 90B and any applicable local ordinance.

WARNING

Do not, under any circumstances, connect return ductwork to any other heat producing device such as fireplace insert, stove, etc. Unauthorized use of such devices may result in fire, carbon monoxide poisoning, explosion, personal injury or property damage.

Sheet metal ductwork run in unconditioned spaces must be insulated and covered with a vapor barrier. Fibrous ductwork may be used if constructed and installed in accordance with SMACNA Construction Standard on Fibrous Glass Ducts. Ductwork must comply with National Fire Protection Association as tested by U/L Standard 181 for Class I Air Ducts. Check local codes for requirements on ductwork and insulation.

- Duct system must be designed within the range of external static pressure the unit is designed to operate against. It is important that the system airflow be adequate. Make sure supply and return ductwork, grilles, special filters, accessories, etc. are accounted for in total flow resistance. Refer to the airflow performance table in this manual.
- Supply plenum is attached to the 3/4" duct flanges supplied with the unit. Attach flanges around the blower outlet.
- Secure the supply and return ductwork to the unit flanges, using proper fasteners for the type of duct used and tape the duct-to-unit joint as required to prevent air leaks.

IMPORTANT

If an elbow is included in the plenum close to the unit, it must not be smaller than the dimensions of the supply duct flange on the unit.

The front flange on the return duct connected to the blower casing must not be screwed into the area where the power wiring is located. Drills or sharp screw points can damage insulation on wires located inside unit.

2.2.7.2 Return air method

Connect the return air pipe at the return air inlet of the indoor unit through the duct to realize air return through air inflow by the blower.

The distance between the mounted indoor unit should meet the specifications illustrated in the following diagram.

Horizontal installations

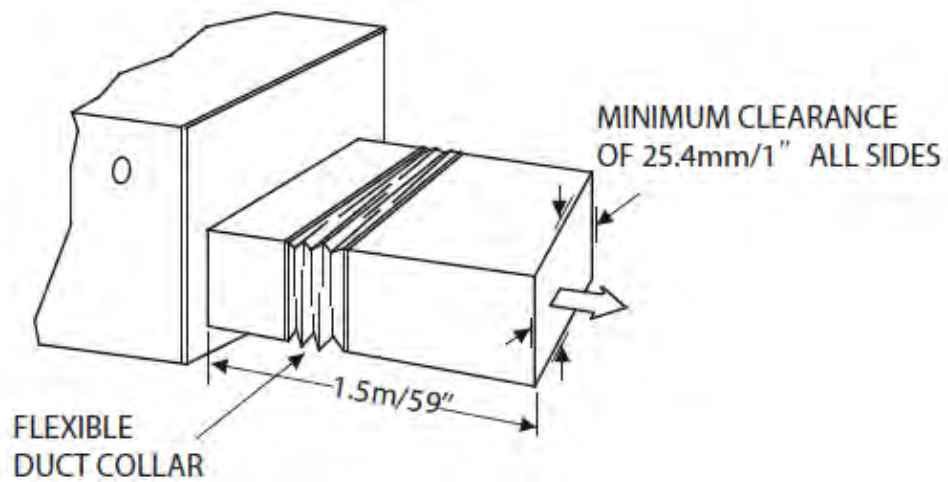

Vertical up installations

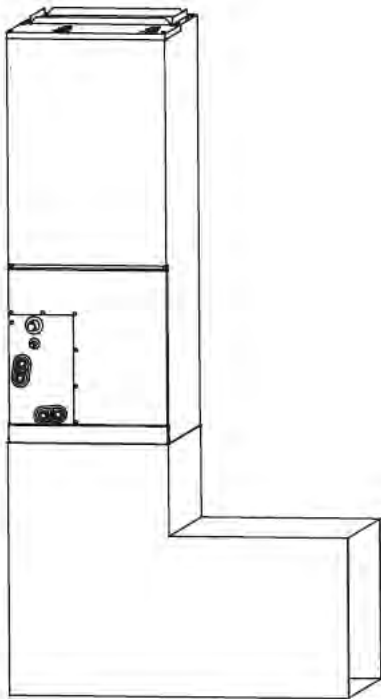

The size of the air outlet is based on A and 10-5/16", and that of the return air inlet is based on D and W. A bracket should be made, with a recommended width of 20mm. (For A, 10-5/16", D and W, please check the picture below)

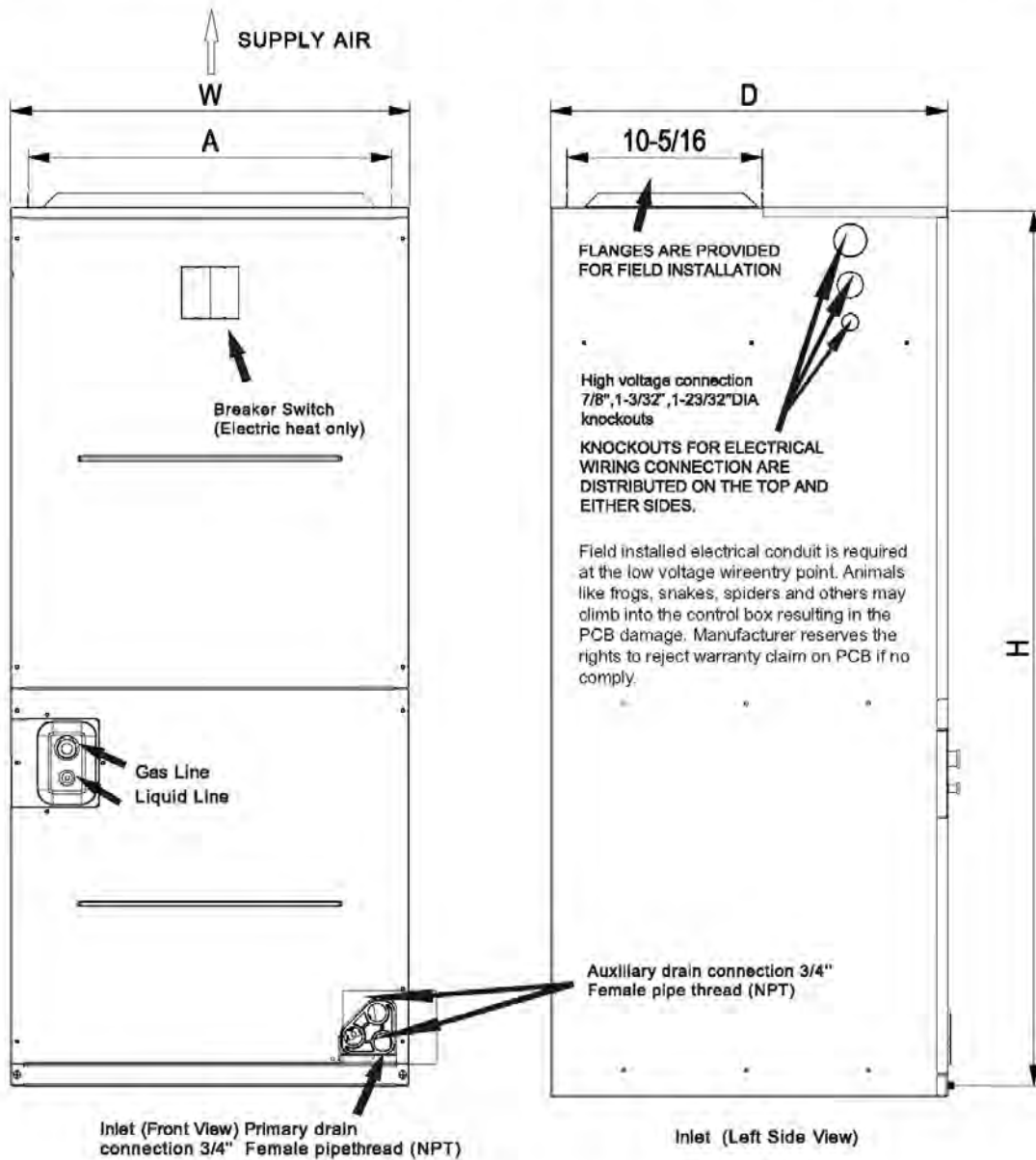

2.3 Electrical installation

2.3.1 Requirement and notice of electrical installation

2.3.1.1. Indoor unit

Dedicated distribution device and wire for air conditioner

Min. circuit ampacity of air conditioner(A)	Minimum wire cross-sectional area(mm ²)	Specification of socket or switch(A)	Fuse specification(A)
≤ 8	0.75	15	15
>8 and ≤ 10	1.0	15	15
>10 and ≤ 15	1.5	20	25
>15 and ≤ 24	2.5	25	40
>24 and ≤ 28	4.0	35	45
>28 and ≤ 32	6.0	40	55

NOTE:

The table above for reference only, the installation shall meet the requirement of local law and regulation.

2.3.1.2. Outdoor unit

2.3.1.2.1. Low voltage wire requirement

Define the maximum length of low voltage wiring from condensing unit to indoor unit and thermostat. Field installed electrical conduit is required at the low voltage wire entry point. Animals like frogs, snakes, spiders and others may climb into the control box resulting in the PCB damage. Manufacturer reserves the rights to reject warranty claim on PCB if no comply.

Table 11-1 Low voltage control wiring requirement

CONTROL WIRING	
Wire Size	Max. Wire Length
18 AWG	164ft

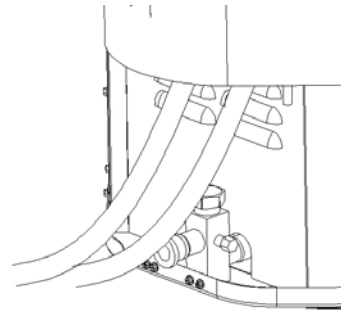

2.3.1.2.2. Low voltage hook-up diagram

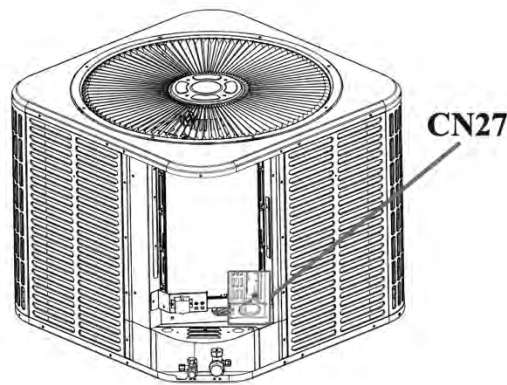
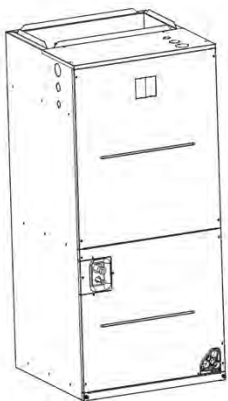

Thermostat wiring harness

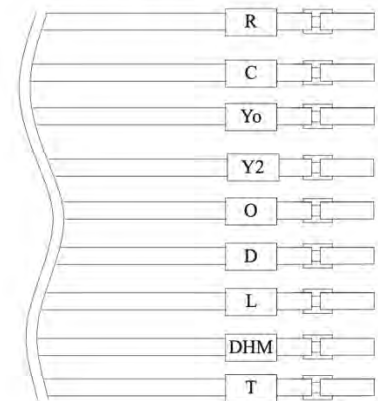

Low voltage control wiring connection

Class 2 low voltage control wiring should not be run in conduit with main power wiring and must be separated from power wiring, unless class 1 wire of proper voltage rating is used.

Low voltage control wiring should be color-coded 18 AWG.

Refer to wiring diagrams attached to indoor and outdoor sections to be connected.

Make sure separation of control wiring and power wiring has been maintained.

2.3.1.2.3. High voltage power supply

WARNING

During installation, testing, servicing, and troubleshooting of this product, it may be necessary to work

with live electrical components.

Failure to follow all electrical safety precautions when exposed to live electrical components could result in death or serious injury.

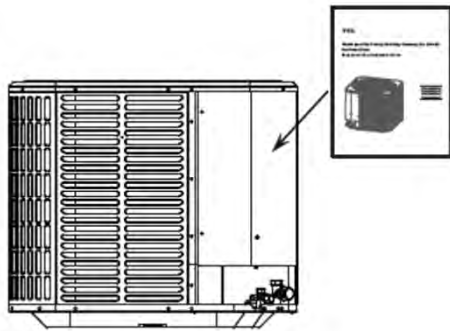

Read the warning label

The high voltage power supply must be in agreement with the equipment nameplate. Power wiring should comply with National, State and Local codes.

Follow instructions on unit wiring diagram located on the inside of the control box cover.

Power Supply			
Model	Voltage	MCA	Breaker
KOIT24H2-41G	280/230V-1Ph-60Hz	14A	25A
KOIT36H2-41G		22A	35A
KOIT48H2-41G		35A	60A
KOIT60H2-41G		35A	60A

2.3.1.2.4. High voltage disconnect switch

Install a separated disconnect switch at the condensing unit. Field provided flexible electrical conduit must be used for high voltage wiring.

In order to get full warranty coverage on the compressor, it's mandatory to install a surge protector to prevent the unit from damaging caused by abnormal electrical spikes.

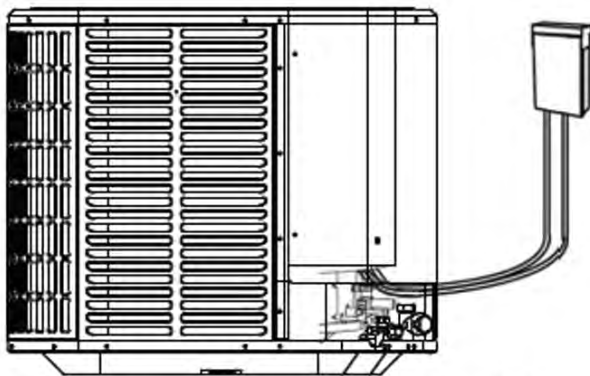

Install an independent switch

2.3.1.2.5. Grounding

Grounding the outdoor unit according to National, State, and Local code requirements.

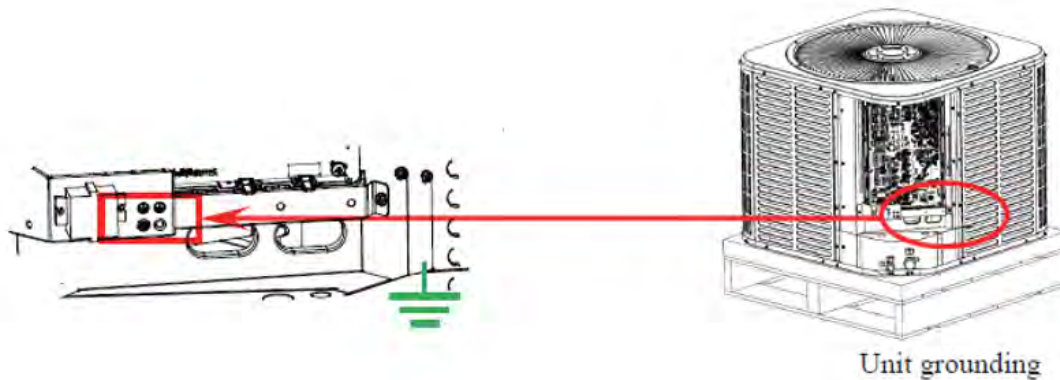

2.3.2 Electrical parameters

2.3.2.1 Wire specification and fuse capacity

Field wiring must comply with the National Electric Code (C.E.C. in Canada) and any applicable local ordinance.

WARNING

Disconnect all power to unit before installing or servicing. More than one disconnect switch may be required to de-energize the equipment. Hazardous voltage can cause severe personal injury or death. Ground the unit according to National, State, and Local code requirements.

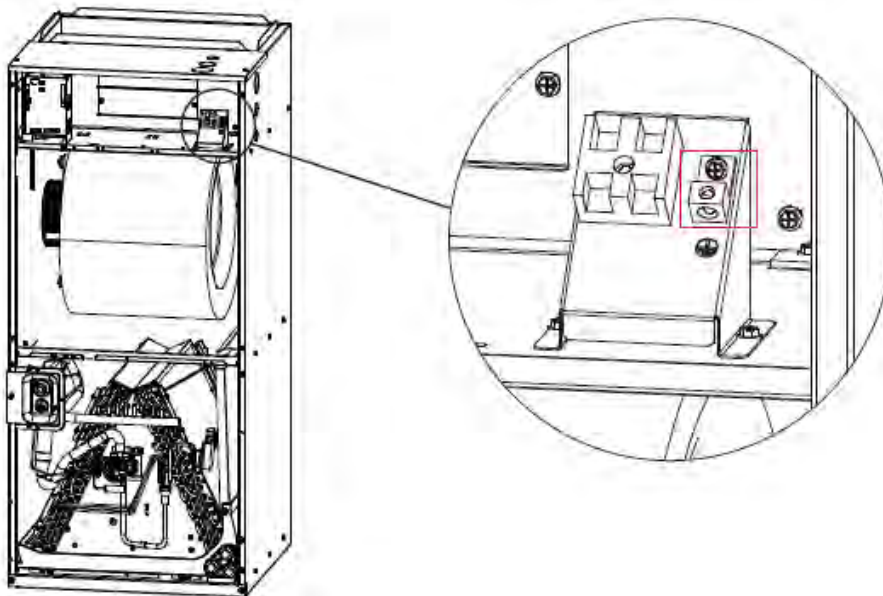

Minimum cross-sectional area of power and signal cables

Wiring material ampacities	AWG
4	22
7	20
10	18
13	16

18	14
25	12
30	10
40	8
55	6
70	4

The ampacities shown apply to appliance wiring materials with insulation rated not less than 90°C (194°F).

Supply circuit power wiring must be copper conductors.

It is important that proper electrical power is available for connection to the unit model being installed. Refer to the unit nameplate, wiring diagram and electrical data in the installation instructions.

- If required, install a branch circuit disconnect of adequate size, located within sight of, and readily accessible to the unit.
- When the electric heater is installed, units may be equipped with one or two 30~60 Amp circuit breakers. These breakers protect the internal wiring in the event of a short circuit and serve as a disconnect. Circuit breakers installed within the unit do not provide over-current protection of the supply wiring and therefore may be sized larger than the branch circuit protection.
- Supply circuit power wiring must be 167 °F minimum copper conductors at least. Refer to electrical data in this section for ampacity, wire size and circuit protector requirements. Supply circuit protective devices may be either fuses or “HACR” type circuit breakers.

2.3.3 Connection of power cord and communication cord

1. The power cable is selected based on the above wire size and local safety regulation (single-phase power supply);

2. 485 communication—The communication line (for indoor and outdoor units, wire controller)

The wired controller and overhead butted wire for the wire controller, 485 communication line for indoor and outdoor units are required.

Installation Diagram

Connect the wire from the master control board of the indoor unit to a connecting cable. Then connect the other side of the connecting cable to the wired control.

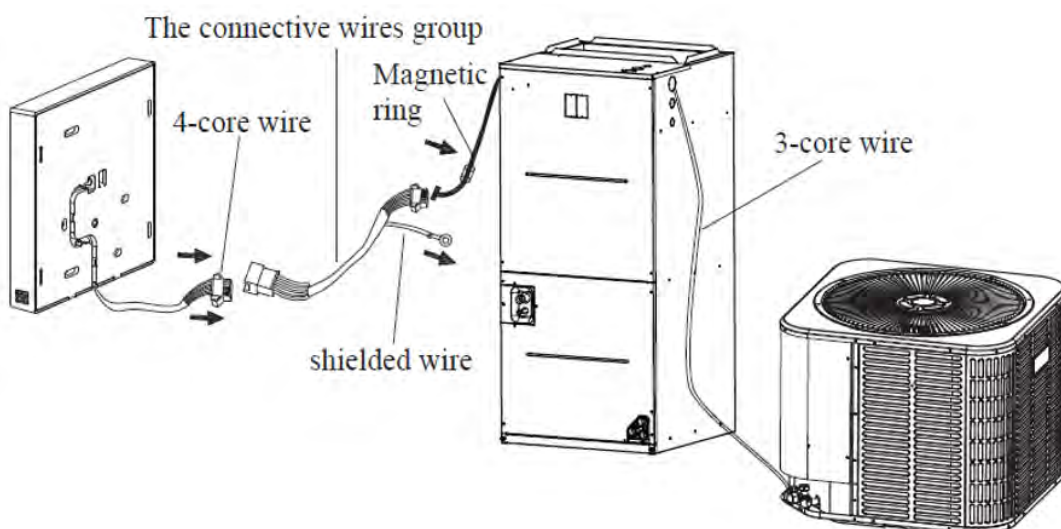

NOTE

Be sure to reserve a length of the connecting wire for periodic maintenance.

There is a connection lug at the end of shielded wire, the connection lug should be properly grounded.

3. The 24V communication (thermostat)

Class 2 low voltage control wiring should not be run in conduit with main power wiring and must be separated from power wiring, unless class 1 wire of proper voltage rating is used.

Low voltage control wiring should be color-coded 18 AWG.

Refer to wiring diagrams attached to indoor and outdoor sections to be connected.

Make sure separation of control wiring and power wiring has been maintained.

2 Stage, 2 Step, Heating Pump

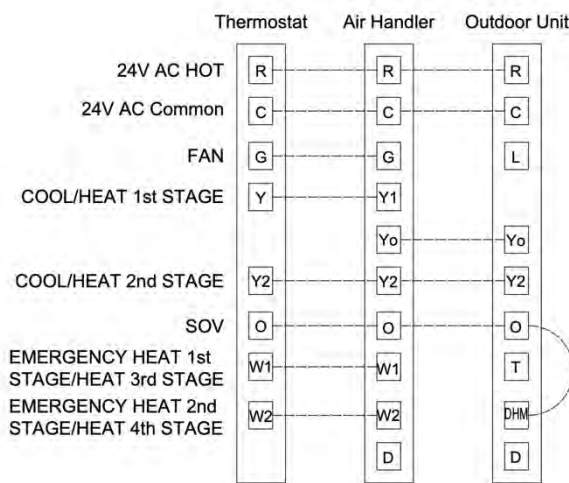

2 Stage, 2 Step, Cooling Only

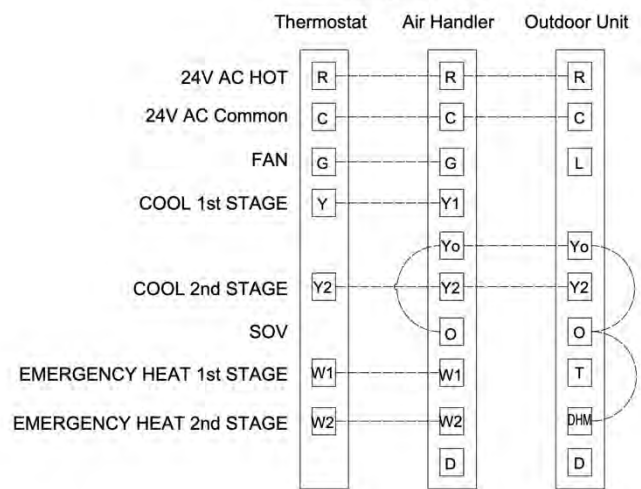

Single Stage, Heating Pump

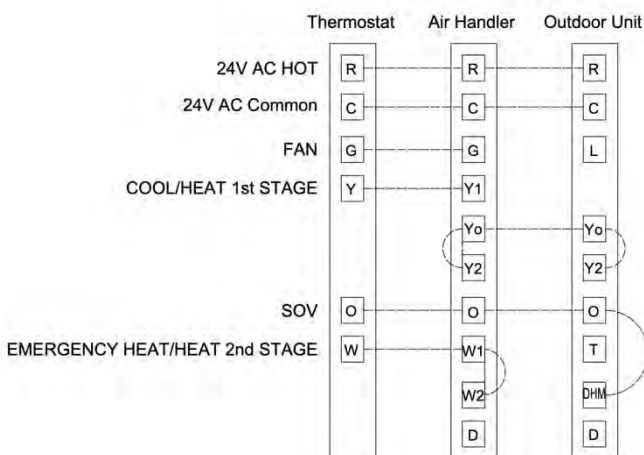

Single Stage, Cooling Only

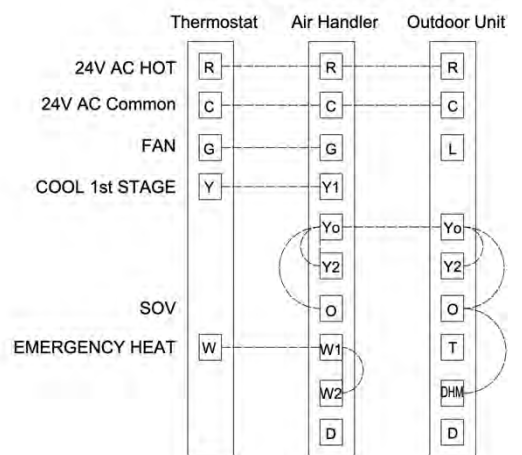

Thermostat wiring harness

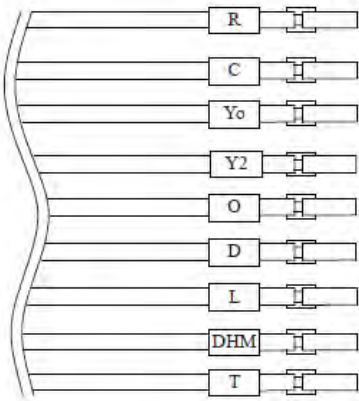

Code	Name
R	24V AC power supply
C	Common
G	Fan
Y1	Low stage
Y2	High stage
O	Cooling four-way valve
W1	Electric heating 1
W2	Electric heating 2
D	Defrost
Yo	Low stage (to outdoor)

2.4 Check after installation

After confirming proper wiring, start the unit for operation. If any problem arises, check the fault code.

WARNING

Electrical safety Precautions.

- 1) Cut off the power supply of air conditioner before checking and maintenance.
- 2) The air conditioner must apply specialized circuit and prohibit share the same circuit with other appliances.
- 3) The air conditioner should be installed in suitable location and ensure the power plug is touchable.
- 4) Make sure each wiring terminal is connected firmly during installation and maintenance.
- 5) Have the unit adequately grounded. The grounding wire can't be used for other purposes.
- 6) Must apply protective accessories such as protective boards, cable-cross loop and wire clip.
- 7) The live wire, neutral wire and grounding wire of power supply must be corresponding to the live wire, neutral wire and grounding wire of the air conditioner.
- 8) The power cord and power connection wires can't be pressed by hard objects.
- 9) If power cord or connection wire is broken, it must be replaced by qualified person.
- 10) If the power cord or connection wire is not long enough, please get the specialized power cord or connection wire from the manufacture or distributor. Prohibit prolong the wire by yourself.
- 11) For the air conditioner without plug, an air switch must be installed in the circuit. The air switch should be all-pole parting and the contact parting distance should be more then 3mm.
- 12) Make sure all wires and pipes are connected properly and the valves are opened before energizing.
- 13) Check if there is electric leakage on the unit body. If yes, please eliminate the electric leakage.
- 14) Replace the fuse with a new one of the same specification if it is burnt down, don't replace it with a cooper wire or conducting wire.
- 15) If the unit is to be installed in a humid place, the circuit breaker must be installed.

2.5 Test running

Blinking definition (For 24V communication only).

The LED lights 200ms **ON** and then 200ms **OFF**, defined as a LED light flashing.

LED light color	LED light status	Failure
Green light	Turn off	Standby mode
Green light	stay lit	In operation
Green light	beat 1	Anti-cold air operation. (blinks once, OFF for 1s)
Green light	beat 2	Auxiliary electric heater works. (blinks twice, OFF for 1s)
Green light	beat 3	For unit commodity inspection only. (blink s3 times, OFF for 1s)
Green light	beat 3	For self-check. (blinks 4 times, OFF for 1s)
Red light	Turn off	Normal operation.
Red light	stay lit	Refrigerant leak protection
Red light	beat 1	The communication of the refrigerant sensor abnormal. (blinks once, and then OFF for 1s).
Red light	beat 2	Internal fan fault. (blinks twice, OFF for 1s)
Red light	beat 3	Indoor coil temperature sensor fault (blinks 3 times, OFF for 1s)
Red light	beat 4	Indoor supply temperature sensor fault (blinks four times, and then disappears for 1s)
Red light	beat 5	EEPROM fault (blinks 5 times, OFF for 1s)
Red light	beat6	Indoor/Outdoor 485 Communication failure (blinking six times, OFF for 1s)
Red light	beat 7	Controller 485 Communication failure (blinking 7 times, OFF for 1s)

NOTE

1. The Red (LED1) and Green (LED2) lights are located on the indoor unit PCB.
2. For 485 Communication, it will show the failure codes on the wired Controller.

3. Maintenance instruction manual

1. Inspections before maintenance.

(1) Inspection of maintenance environment

- There should be **no leaked refrigerant** in the room before operation.
- It is only allowed to operate in a room which meets the area requirement on the nameplate.
- It is necessary to make the room keep a continuous **ventilation** state at the time of maintenance.
- The room in the maintenance should be free from **fire or welding, smoking, drying oven** or any other goods temperature higher than **396°C / 745° F (R454B)** which easily produces fire.
- During the maintenance, it is necessary to ensure that any person's any **mobile phone** or any **electronic product** with radiation in the room is powered off.
- The maintenance area should be equipped with a drying powder or carbon dioxide **fire extinguisher** and that such fire extinguisher can work.

(2) Inspection of maintenance equipment

- Check the maintenance equipment is applicable to the refrigerant or not and it is only allowed to use the **professional equipment** recommended by the air conditioner manufacturer.
- Check the **refrigerant leak detector** whether has been calibrated. The set maximum alarm concentration of the refrigerant leak detector should not exceed 25% of the lower explosion limit (LEL), the refrigerant leak detector must be working during maintenance.

(3) Inspection of air conditioner

- It is necessary to ensure that the air conditioner is in reliable **ground connection** before maintenance.
- Make sure **powered supply** to air conditioner is off. Before maintenance, it is necessary to cut off the power and discharge the capacitor power which used in the air conditioner. If it is a must to need the power supply during the maintenance, it is necessary to do ongoing leak detection at the most dangerous position/point in order to avoid potential danger.
- Check the warning labels on the air conditioner whether are in good condition. It is necessary to replace the damaged or smeared warning labels.

(4) Leak inspection before maintenance

Before maintenance, use the **leak detector** or **concentration detector** (pump-type) recommended by the corresponding air conditioner manufacturer to check the air conditioner leak or not.

WARNING

If leak may exist, it is necessary to move all the fire out from the site or extinguish fire and then immediately shut off the air conditioner. Meanwhile, it is necessary to make sure well-ventilated.

4. Safety principles during the maintenance

- At the time of maintenance, it is necessary to ensure well-**ventilation** on the site.
- It is prohibited to use fire including welding, smoking or other purposes. It is prohibited to use mobile phones.
- At the time of maintenance, if the relative humidity is lower than 40%, it is necessary to wear **anti-static** clothing and gloves.

- If the combustible refrigerant is found leaking during the maintenance, it is a must to immediately take forced ventilation and plug up the leak source.

If the product is damaged to the extent that it is a must to open the refrigerating system for maintenance, it is a must to carry the product back to the maintenance station for maintenance. (It is prohibited to weld the refrigerant pipe and do other operations on the user's site.)

- It is necessary to return the air conditioner to its initial state if it is necessary to provide visiting service again due to lacking spare part during the maintenance. Moreover, it is a must to ensure that the refrigerating system is in secure **ground connection**.
- If it is necessary to provide visiting service with a refrigerant cylinder, the volume of refrigerant filled in such refrigerant cylinder should not exceed the stipulated value. When such cylinder is stored in a vehicle or placed on the installation or maintenance site, it is necessary to place it vertically and securely and keep it away from any place where there is any heat source, combustion source, radiation source or electrical equipment.

5. Requirements for the site of maintenance-station

- The maintenance location should be **well-ventilated**, with leveled ground and not in a basement.
- The maintenance should be divided into welding and non-welding areas both of which should be labeled clearly. There should be a certain safety distance between the two areas. The maintenance location should be equipped with ventilating and air-exhausting equipment to prevent the refrigerant gas from aggregating.
- It is necessary to provide some relevant instruments such as combustible refrigerant **leak detector** and have a leak detecting instrument management system. It is necessary to confirm that the leak detector can work normally before maintenance.
- The main **power switch** should be set outside the maintenance location and equipped with protective (explosion-proof) devices.
- It is necessary to provide firefighting devices such as dry powder or carbon dioxide fire **extinguisher** appropriate for extinguishing the electrical fire and keep such firefighting devices in a usable condition.
- Temporary wires and sockets are prohibited on the maintenance location.

6. Requirements for fill the refrigerants

- It is necessary to use **nitrogen** to clear the cyclic system before operating the refrigerating system and vacuumize the outdoor unit for 30 minutes at least.
- It is necessary to ensure that there is no cross contamination among different refrigerants when the refrigerant filling device is used. The total length including the refrigerant pipeline should be as short as possible in order to reduce the residual refrigerant inside such pipeline.
- It is necessary to vertically place the refrigerant storage tanks.
- It is necessary to ensure that the refrigerating system is in **ground** connection before the refrigerant is filled.
- When filling the refrigerant, it is necessary to fill corresponding type and volume of refrigerant as per the requirements on the product nameplate and overfilling is prohibited.
- It is necessary to seal the system in a safe sealing way after maintaining the refrigerating system.
- It is necessary to ensure that the maintenance will not damage or reduce the safety protection grade of the original system.

7. In-maintenance welding

- It is necessary to ensure that the maintenance location is well-**ventilated**.
- Before welding the outdoor unit, it is a must to confirm that the refrigerating system has been drained and the system has been cleaned and ensure that there has been no refrigerant in the outdoor unit.
- It is necessary to close the stop valve of the outdoor unit when using a welding gun to do the maintenance work such as cutting and welding.

8. Maintenance of electrical components

- It is necessary to use a special **leak detector** to check whether the maintained electrical parts location have the leak refrigerant.
- It is not allowed to refit, remove or cancel any component with the safety protection function after finishing the maintenance process.
- When maintaining the sealed parts, it is necessary to turn off the power of air conditioner before opening the sealing cover. When power supply is needed, it is necessary to do the ongoing leak detection at the most dangerous position in order to prevent potential danger.
- It is necessary to specially note that the maintenance of electrical components will not affect the replacement of protective cover.
- In order to ensure that the sealing function is not damaged after maintenance or the sealing material will not lose the effect of preventing the combustible gas leak due to ageing. So the substitute components should meet the requirements recommended by the air conditioner manufacturer.

WARNING

Before doing the trial operation after finishing the maintenance, it is a must to use a practical leak detector to inspect the leakage and reliability of ground connection in order to ensure that no refrigerant leakage and reliable ground connection.

The refrigerant storage tanks should be separately placed in a well-ventilated place at the temperature ranging from -10°C to 50°C / 14° F to 122° F and label them with warning labels.

9. Emergency Accident Handling

A maintenance station should establish emergency handling plans. It is necessary to take appropriate precautionary measures in work. For example, it is prohibited to enter the location with any kindling material and it is prohibited to wear clothing or shoes which easily produce static.

Handling suggestions when a large amount of combustible refrigerant leaks:

- It is necessary to immediately operate the ventilating equipment while cutting off other power supply and evacuating the affected personnel urgently from the location.
- It is necessary to inform near residents of evacuating for over 20 meters / 66 feet from the location, make an alarm call, set the emergency area and prohibit irrelevant personnel and vehicles from approaching.
- The professional firefighters should wear anti-static clothing to handle the emergency on the site and cut off the source of leak.

It is necessary to use nitrogen for blowing the site, especially the low-lying positions, clear away the residual combustible refrigerant gas from any area nearby and surrounding the leak point and use a handheld detector for detection and not clear the alarm until the concentration of refrigerant is zero.

3.1 Control

3.1.1 Operation mode

3.1.1.1 Cooling mode

1. When the indoor unit receives a cold start signal from the temperature controller or wire controller, it will start the blower, and run in the corresponding wind speed according to the Y1/Y2 signal of the temperature controller or the set wind speed of the wire controller, when the indoor unit receives a cold shutdown signal from the temperature controller or wire controller, the fan will stop running after a short delay.

2. When the outdoor unit receives a cold start signal from the temperature controller or wire controller, it will start the blower and compressor, and adjust the speed of the outdoor blower and compressor automatically according to the Y1/Y2 signal of the temperature controller or the set temperature difference of the wire controller, when the outdoor unit receives a cold shutdown signal from the temperature controller or wire controller, it will stop running after a short delay.

3.1.1.2 Heating mode

1. When the indoor unit receives a heat start signal from the temperature controller or wire controller, it will start the blower, and run in the corresponding wind speed according to the Y1/Y2 signal of the temperature controller or the set wind speed of the wire controller, when the indoor unit receives a heat shutdown signal from the temperature controller or wire controller, the fan will stop running after a short delay.

2. When the outdoor unit receives a heat start signal from the temperature controller or wire controller, it will start the blower and compressor, and adjust the speed of the outdoor blower and compressor automatically according to the Y1/Y2 signal of the temperature controller or the set temperature difference of the wire controller, it will stop running after a short delay, the outdoor unit may enter the defrosting mode during heating. At this point, the internal and external blowers may stop running, the four-way valve will switch to the cooling mode, and the compressor will enter the defrosting mode for defrosting at the corresponding speed.

3.1.1.3 Emergency heat mode

While the indoor unit is provided with electric auxiliary heating, if it receives an emergency heating mode signal from the temperature controller or wire controller, the blower will start running. The electric auxiliary heater will start automatically according to the W1/W2 signal of the temperature controller or the set temperature difference of the wire controller. In the emergency heating mode, the indoor blower will maintain a high wind speed and the outdoor unit will not run. When receiving a shutdown signal from the thermostat or wire controller, the electric auxiliary heater will shut down and the fan will stop running after a short delay.

3.1.2 Control mode

3.1.2.1 Based control

3.1.2.1.1 Compressor control

Under different modes, the compressor can only be stopped after running for some time (special cases exclude). This is to protect the compressor from frequent start or stop. Once the compressor is stopped, it must not be restarted right away, please wait for a few minutes.

3.1.2.1.2 EXV control

When the unit is first started, the electronic expansion valve will reset control. During the process, the expansion valve will produce rattling sound. When cooling mode is turned on, the valve will be opened at the max step before the compressor starts. When heating mode is turned on, the valve will be opened at a certain step before the compressor starts.

3.1.2.1.3 Indoor fan control

The indoor fan can run at the highest level 7 and the lowest level 1. When a 24V control thermostat is used, the indoor blower may only operate at up to two speeds. When the RS485 communication wire controller is used, the indoor blower can operate at seven speeds according to the wind speed set by the wire controller. In the heating mode, the indoor blower may stop running when the outdoor unit is defrosting.

3.1.2.1.4 Outdoor fan control

The outdoor fan can run at the highest level 5 and the lowest level 1. By controlling the speed of outdoor fan, the unit can achieve cooling at low temperature. In fan mode, outdoor fan will not work.

3.1.2.1.5 Four-way valve control

The four-way valve of the outdoor unit is in a power-off state during cooling mode. When switching to heating, it will change its direction, resulting in a change in the refrigerant circulation path and realizing the heating function. In the heating mode, if the outdoor unit starts defrosting, the four-way valve will be powered off again during defrosting, resulting in a change in the refrigerant circulation path and realizing the defrosting effect.

3.1.2.2 Special control

3.1.2.2.1 Oil return control

When the outdoor unit is operating at a low frequency for a long time, to ensure the reliability of the unit, the compressor speed will be increased automatically during the set time period for oil return operation, and the digital display will show **4**. At this point, the operating mode of the unit remains unchanged, and the compressor speed, outdoor blower speed, and electronic expansion valve openness will be adjusted to the corresponding parameters of the oil return mode. After 5 minutes, the unit will exit from the oil return mode and the original operating state will be restored.

3.1.2.2.2 Defrost control

When the system is in the heating mode, the detected temperature of the outdoor coil will be lower than the set value due to frosting, and the unit will enter the defrosting mode. The digital display of the outdoor unit will show **5**, the outdoor blower will stop, the four-way valve will switch to the cooling state, and the compressor will run at the defrosting speed for defrosting. After continuous running for some time, if the outdoor tube temperature exceeds the set value for exiting from defrosting, the unit will exit from the defrosting mode and resume operation in the original mode.

3.1.2.2.3 Warm-up control for outdoor unit winding

To avoid the migration of refrigerant into the compressor at low temperatures, which may lead to poor oil return or difficult startup of the unit, the unit is provided with the winding preheating function. When the outer ring temperature is lower and the compressor is in the stop state, the controller will apply a certain current value to the compressor winding coil to warm it up and heat the compressor oil sump. It is advised

to keep warming up the unit for 2 hours before starting the unit when the outer temperature is too low.

3.1.2.2.4 Forced start

In special circumstances where it is impossible to start the unit normally through the temperature controller or wire controller, or when refrigerant recovery is required, the unit can be started through the forced operation function.

When the outdoor unit is in the standby mode, hold down **KEY4 for 3 seconds** and then release it. The unit will enter the forced **cooling mode**, and the digital display of the outdoor unit will show **7**;

When the outdoor unit is in the standby mode, hold down **KEY4 for 6 seconds** and then release it. The unit will enter the forced **heating mode**, and the digital display of the outdoor unit will show **8**.

3.1.2.3 Protection control

3.1.2.3.1 High pressure protection control

System will enable high pressure protection control if the high-pressure switch is detected open for continuously a little time. Under high pressure protection, system will be shut down.

When high pressure protection occurs for the first time, system will restore operation if the high-pressure switch is detected to be reclosed for continuously a little time. When high pressure protection occurs for the second time in a certain time period, system will not restore operation. You need to manually turn off the unit and clear the error before restarting up the unit. (If high pressure protection occurs frequently, please send for professional personnel to repair it.)

3.1.2.3.2 Low pressure protection control

System will enable low pressure protection control if the low-pressure switch is detected open for continuously a little time. Under low pressure protection, system will be shut down.

When low pressure protection occurs, system will restore operation if the low-pressure switch is detected to be reclosed within a few minutes after shutdown. If low pressure protection occurs for several times in a period of time, system will not restore operation automatically. You need to manually turn off the unit before restarting up the unit.

3.1.2.3.3 Refrigerant leakage protection

When refrigerant leakage occurs in the indoor unit, the refrigerant leakage sensor will trigger an alarm, and the outdoor unit will stop running. The indoor unit's wind speed will be adjusted to the maximum wind speed automatically to dilute the refrigerant concentration.

When a refrigerant leakage alarm occurs, a professional must be notified to confirm the leakage problem on site, and the unit can be powered on again after troubleshooting only.

3.1.3 Functions

(when RS485 wire controller is required) (refer to the instruction manual for wire controller)

Function:

Mode: Auto - Cool - Dry - Fan -Heat - Emergency Heat

Fan speed: Mute /Low/Med-low/Med/Med-high/High speed/Turbo/Auto

Timer ON/OFF

Temp setting

Weekly timer

24-hour System

12-hour System

Auto-restart (on some models)

Child Lock

LCD display

Clock

Panel function (on some models)

3.2 troubleshooting

3.2.1 Wiring diagrams

Wiring diagram of indoor unit

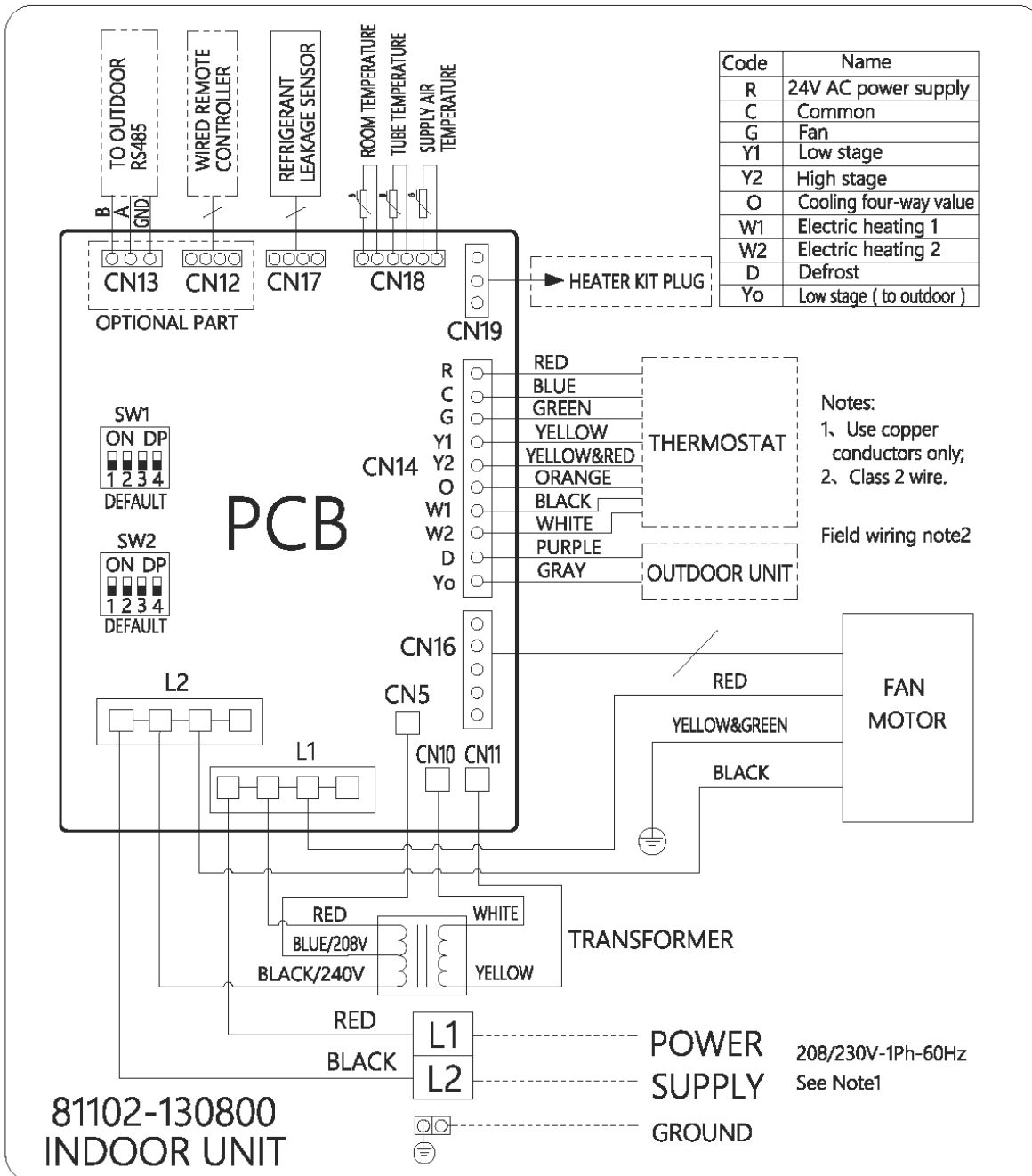

Wiring diagram of outdoor unit

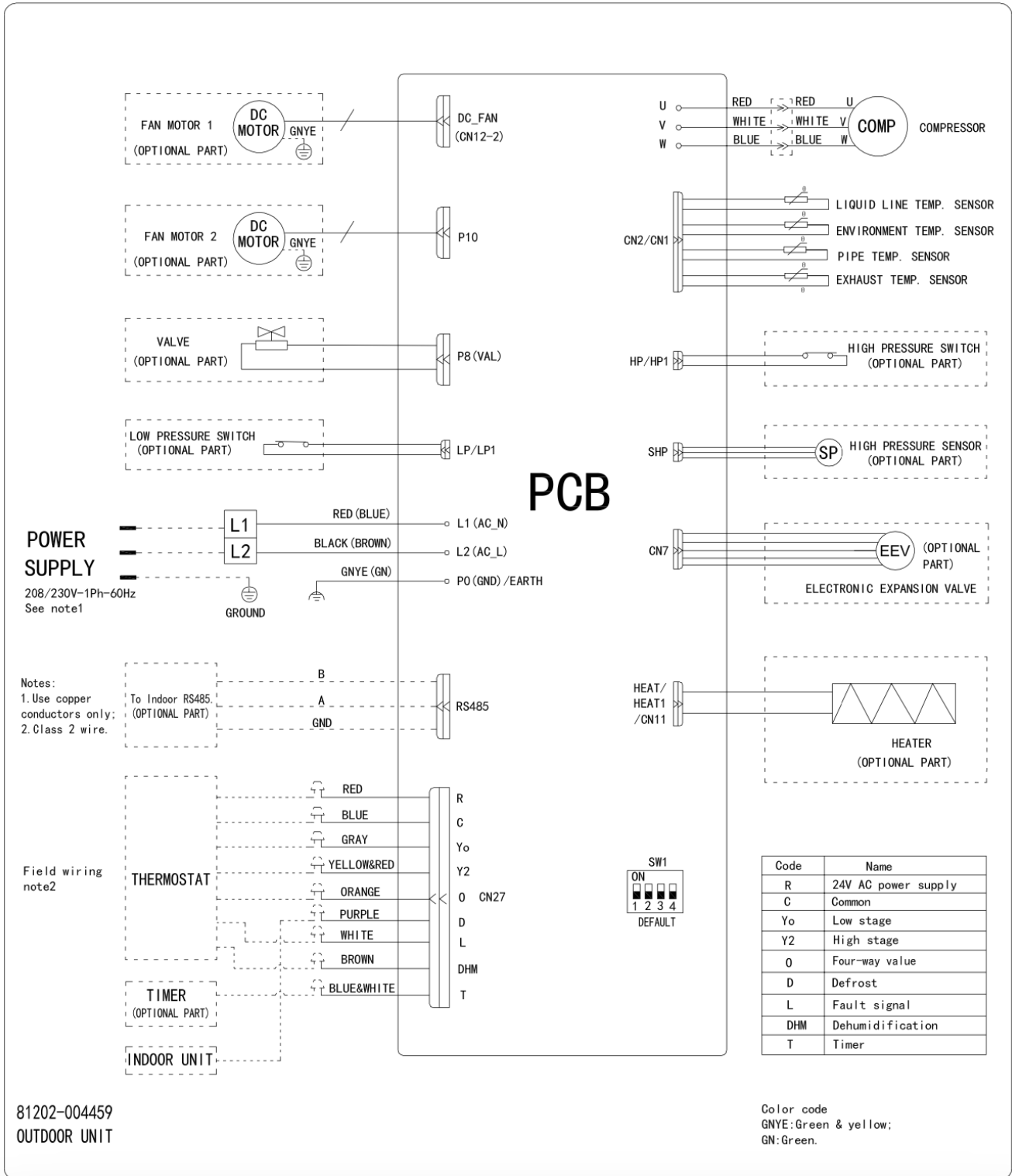

3.2.2 PCB Layout

Electric control of indoor unit

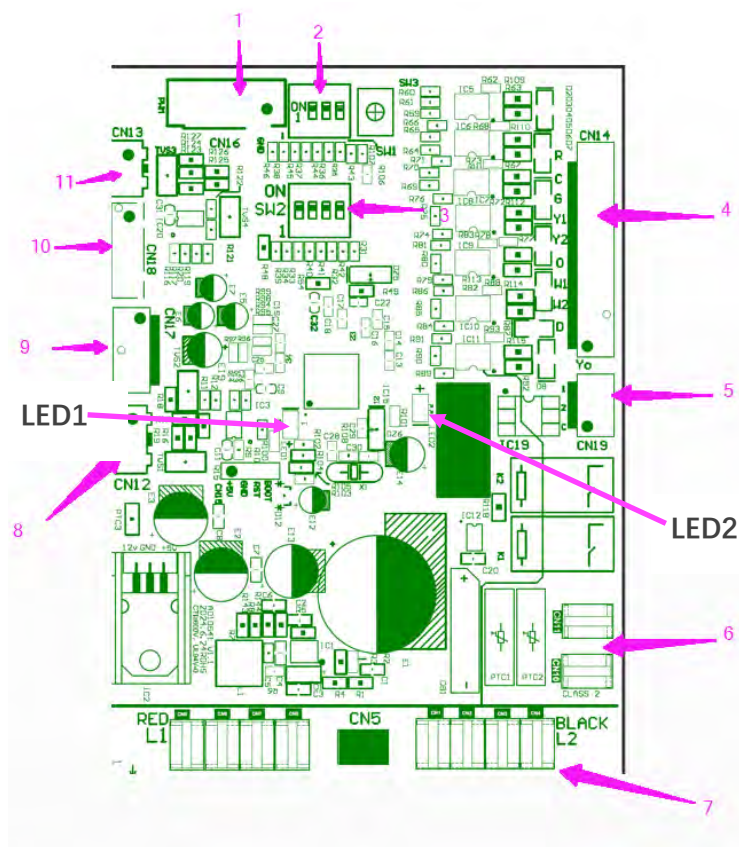

1	Fan motor
2	Dual In-line package switch 1
3	Dual In-line package switch 2
4	24V AC Thermostat
5	Heater
6	AC 24V power supply
7	AC208/230 60Hz power supply
8	Wired remote controller
9	Refrigerant sensor
10	Temperature sensor
11	Outdoor 485
	LED1 (Red)
	LED2 Green)

Electric control of outdoor unit

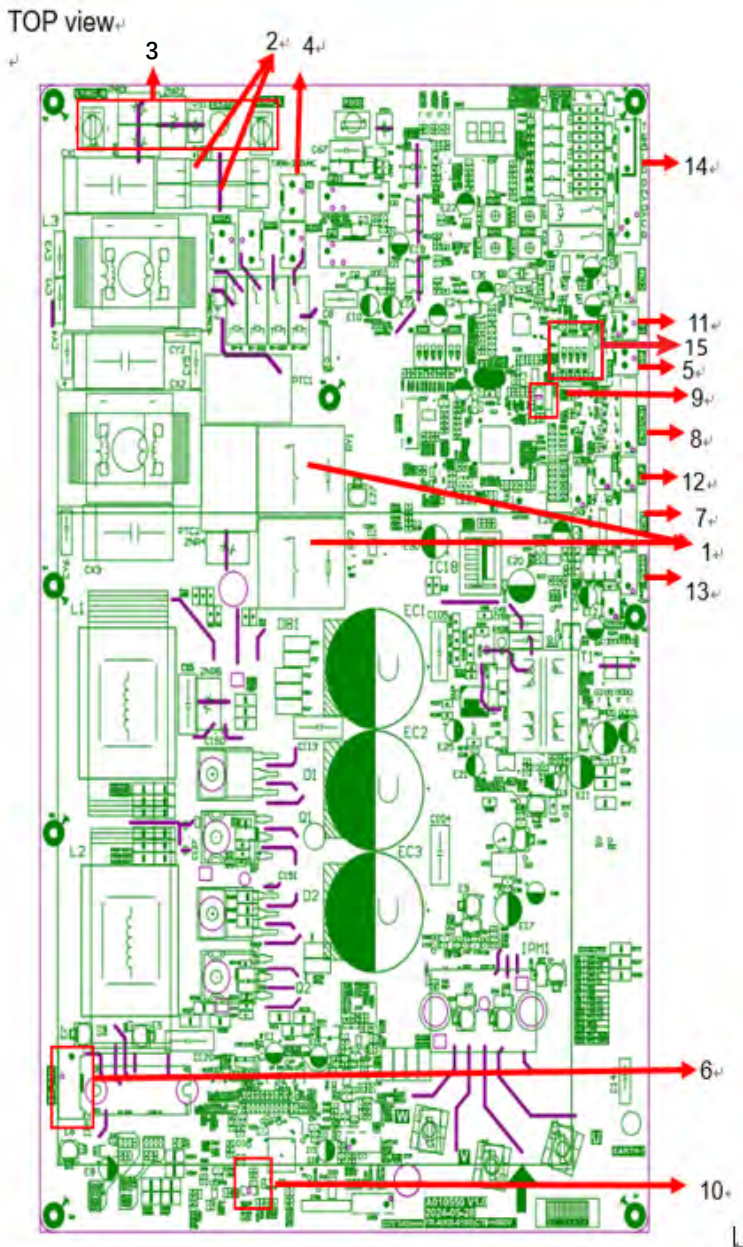

1	ODU PCB Mainly relay
2	Fuse
3	L1, L2 & P0
4	4-way valve
5	High pressure switch (HP)
6	DC fan motor connector
7	EEV
8	Temperature sensors connector
9	LED2 (Red)
10	LED1 (Red)
11	Low pressure switch (LP)
12	Pressure sensor (SHP)
13	RS485
14	AC 24V power supply
15	Dual In-line package switch 1

NOTE

LED1---- Indicates the main control IC works condition.

When unit works normal----LED1 flashing
 When unit works abnormal ----LED1 OFF.

LED2-----Indicates the compressor / DC motor driving IC status:

When unit works normal----LED2 flashing
 When unit works abnormal ----LED2 OFF.

3.2.3 Error codes

Code	Reason	Remark
E0	IDU & ODU Communication failure	The IDU & ODU wiring connection correct?
E1	IDU Room temperature sensor failure. (IDU RT failure)	IDU room sensor and PCB.
E2	IDU Tube temperature sensor failure. (IDU IPT failure)	IDU coil sensor and PCB.
E3	ODU Pipe temperature sensor failure. (OPT)	ODU pipe sensor and ODU PCB
E6	IDU PG Fan motor / DC fan motor works abnormal (IDU failure)	Fan motor, fan blade and PCB.
E7	ODU Environment temperature sensor failure	ODU environment sensor and ODU PCB.
E8	ODU Exhaust temperature sensor failure.	ODU exhaust sensor and ODU PCB.
E9	IPM / Compressor driving control abnormal.	ODU PCB, compressor, etc.
EA	ODU Current test circuit failure	ODU PCB broken?
Eb	The main PCB and display board communication abnormal	Display board and ODU PCB.
EC	The ODU PCB MCU and Fan motor / Compressor driving IC communication abnormal	ODU main PCB
EE	ODU EEPROM failure.	ODU PCB broken? Try to re-power on AC unit.
EF	ODU DC fan motor failure.	Fan motor, ODU PCB.
EU	ODU Voltage test circuit abnormal.	ODU PCB.
Ey	ODU Condenser outlet temperature sensor failure	ODU Condenser outlet sensor and ODU PCB.
P0	IPM module protection.	ODU PCB
P1	Over / under voltage protection.	ODU PCB broken? Power supply abnormal?
P2	Over current protection.	ODU PCB broken? Power supply abnormal?
P4	ODU Discharge pipe over temperature protection.	Please check the troubleshooting for detail.
P5	Sub-cooling protection on cooling mode.	Please check the troubleshooting for detail.
P6	Overheating protection on cooling mode.	Please check the troubleshooting for detail.
P7	Overheating protection on heating mode.	Please check the troubleshooting for detail.
P8	Outdoor Over temperature/Under temperature protection.	Please check the troubleshooting for detail.
P9	Compressor driving protection (Load abnormal).	Please check the troubleshooting for detail.
F0	Infrared Customer feeling test sensor failure. (IDU failure)	Querying by press remote controller

F1	Electric power test module failure. (IDU failure)	Querying by press remote controller
F2	Discharge temperature sensor failure PROTECTION.	1. The discharge temperature sensor damage 2. The discharge temperature sensor connection is loose 3. ODU main PCB damage
F3	ODU coil temperature failure PROTECTION.	1. The coil temperature sensor damage 2. The coil temperature sensor connection is loose 3. ODU main PCB damage
F4	Cooling system gas flow abnormal PROTECTION.	Please check the troubleshooting for detail.
F5	PFC PROTECTION	Please check the troubleshooting for detail.
F6	The Compressor lack of phase / Anti-phase PROTECTION.	Please check the troubleshooting for detail.
F7	IPM Module temperature PROTECTION	Please check the troubleshooting for detail.
F8	4-Way Value reversing abnormal.	Please check the troubleshooting for detail.
F9	The module temperature test circuit failure.	ODU PCB
FA	The compressor phase-current test circuit failure.	ODU PCB
Fb	Limiting/Reducing frequency for over load protection on Cooling/Heating mode.	Querying by press remote controller
FC	Limiting/Reducing frequency for high power consumption protection.	Querying by press remote controller
Fd	The communication of refrigerant detection sensor and indoor PCB abnormal	The refrigerant sensor disengaged or faulty.
FE	Limiting/Reducing frequency for module current protection (phase current of compressor).	Querying by press remote controller
FF	Limiting/Reducing frequency for module temperature protection.	Querying by press remote controller
FH	Limiting/Reducing frequency for compressor driving protection.	Querying by press remote controller
FP	Limiting/Reducing frequency for anti-condensation protection.	Querying by press remote controller
FU	Limiting/Reducing frequency for anti-frost protection.	Querying by press remote controller
Fj	Limiting/Reducing frequency for discharge over temperature protection.	Querying by press remote controller
Fn	Limiting/Reducing frequency for ODU AC current protection.	Querying by press remote controller
Fy	Gas leakage protection	Please check the troubleshooting for detail.
H1	High pressure switch failure (HP)	1. High pressure switch damage 2. High pressure switch loose connection

		3. ODU main PCB damage
H2	Low pressure switch failure (LP)	1. Low pressure switch damage 2. Low pressure switch loose connection 3. ODU main PCB damage
H3	High pressure sensor failure (SHP)	1. high pressure sensor damage 2. high pressure sensor loose connection 3. ODU main PCB damage
H4	Low pressure sensor failure (SHP)	1. Low pressure sensor damage 2. Low pressure sensor loose connection 3. ODU main PCB damage
Hd	Excessive refrigerant concentration / refrigerant leakage	1. Is there R454B gas leakage? 2. Are there polluting gases around the environment? 3. Refrigerant test sensor fault? 4. Indoor PCB defective?
C5	Communication fault of the Wired Controller and indoor unit main PCB.	1. Check the connection of the wired controller and PCB; 2. Indoor PCB defective? 3. The wired controller failed?
dA	The indoor supply air temperature sensor failure	Check the sensor and PCB

Note: Remote controller FAILURE CODE Querying function

As shown in the failure codes, some of the codes (Fb~bj) need to press remote control for inspection. While unit on operation, press the ECO button 8 times with 8 seconds, the buzzer BIBI 2 times, you can inspect the special failure code as Fb~Fn, bj etc.

3.2.4 Trouble shooting

3.2.4.1 E0 --IDU & ODU communication failure

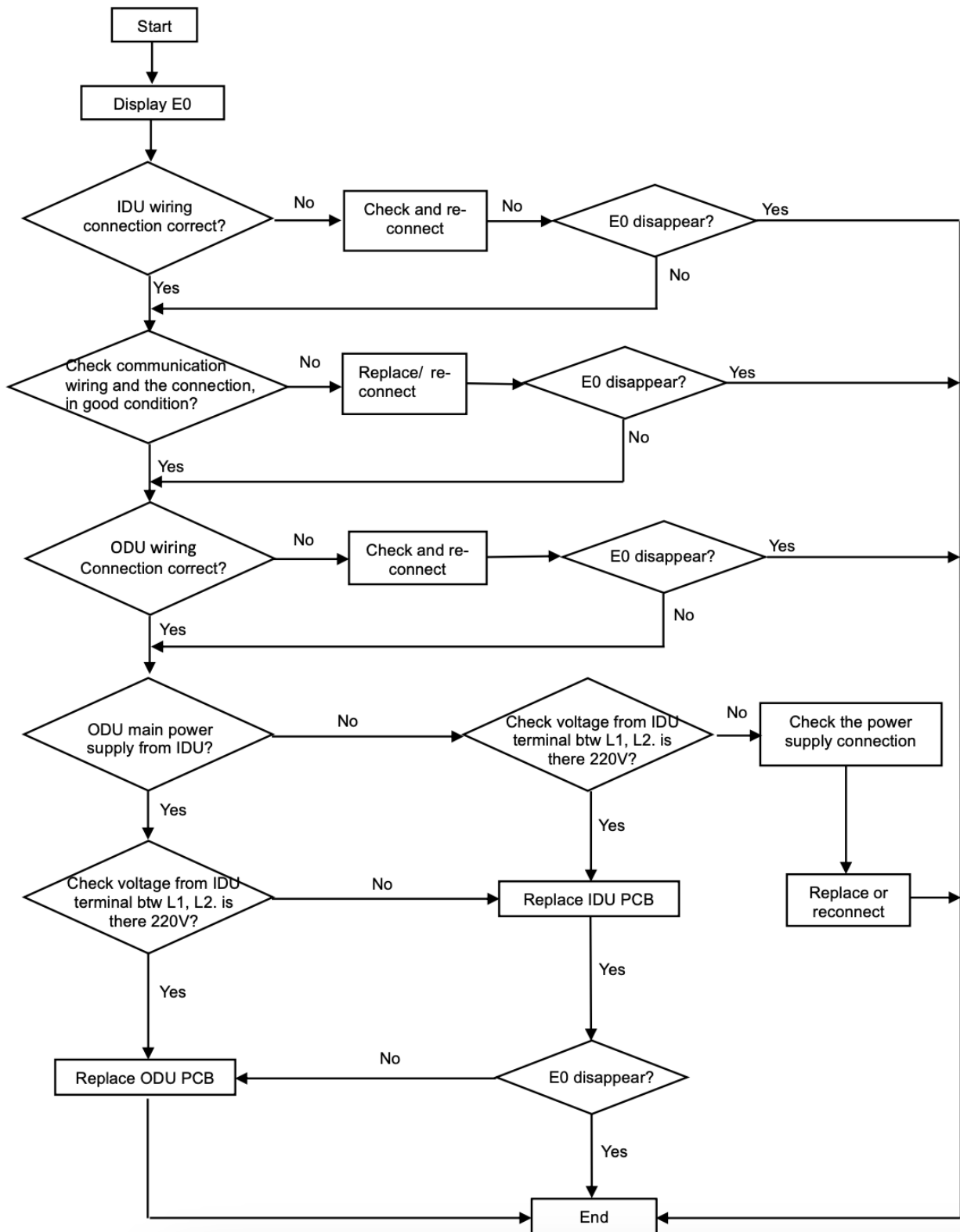

3.2.4.2 E3, E7, E8 or Ey---ODU Coil temperature sensor, Ambient temperature sensor or Discharge temperature sensor, Condenser outlet temperature failure.

When any of sensor resistance open or short circuit, the unit will display failure code as E3, E7, E8 or Ey, IDU and ODU turns off. When the sensor resistance recovery, unit revert to be standby, customer can switch on the unit directly.

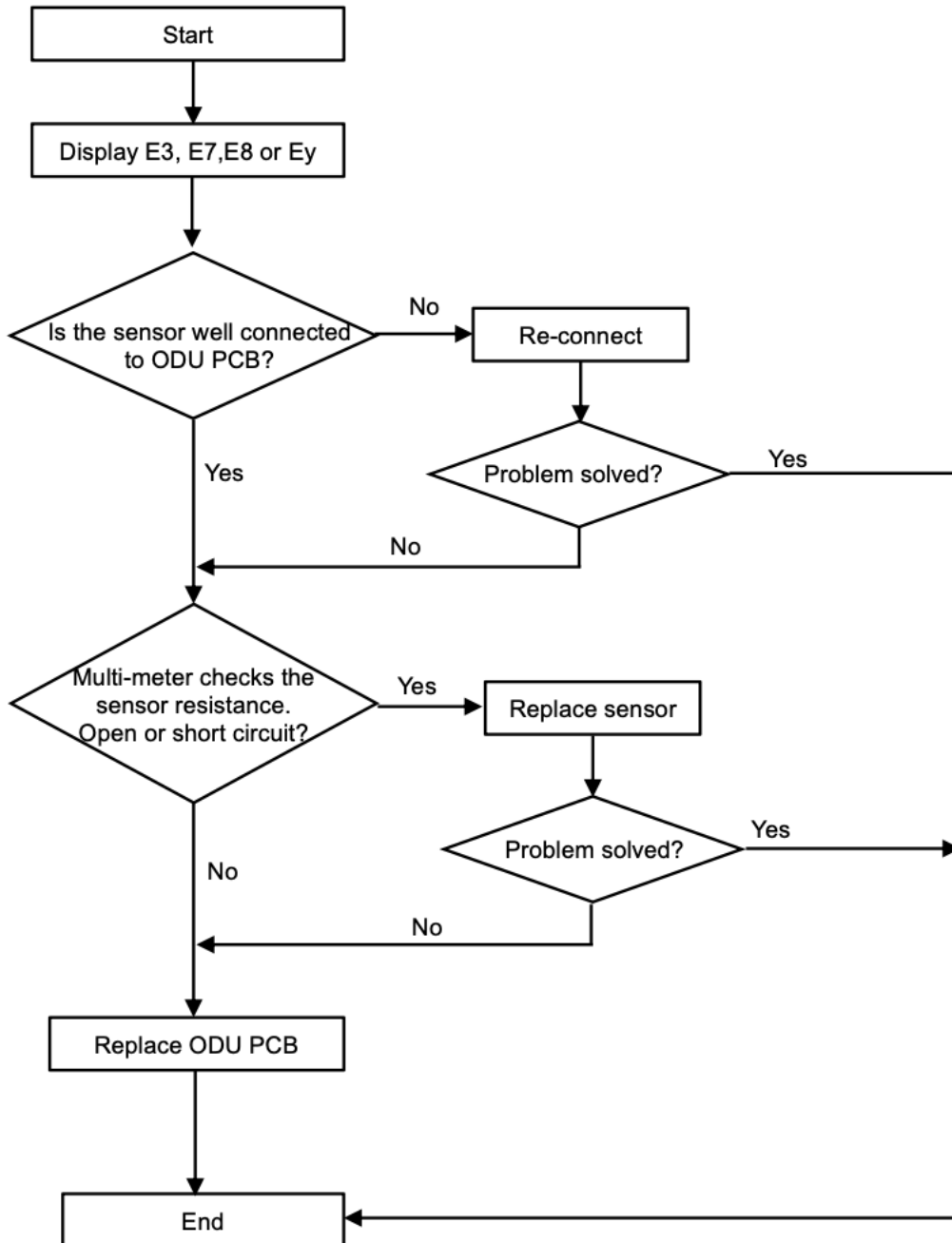

3.2.4.3 E9---ODU IPM /Compressor driving fault

If unit have 6 times stopping works for IPM protection continuously, it will display E9 error, and unit can't be recovered to operation, except press ON/OFF button.

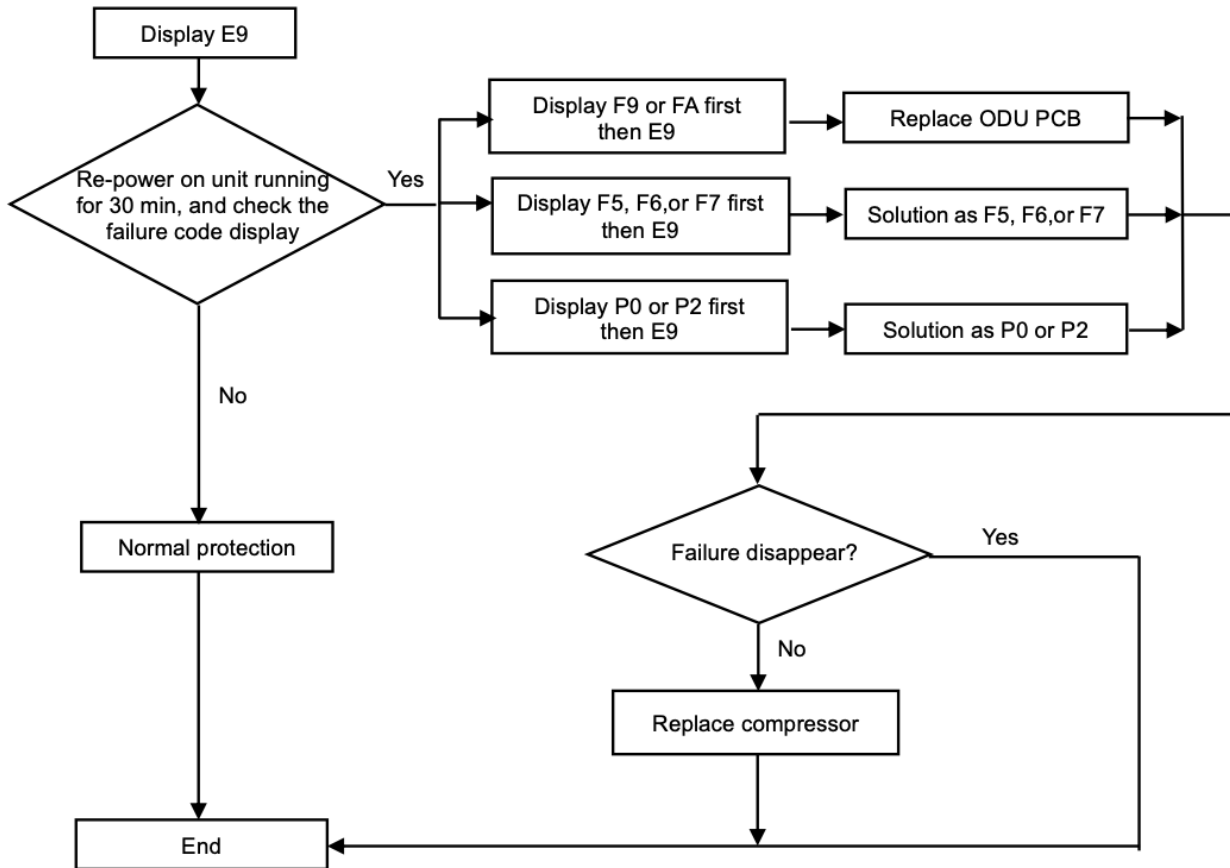

3.2.4.4 EA—ODU current sampling failure

Cause: Outdoor current sampling circuit failure or driver parameter mismatch

Solution: Replace the ODU PCB.

3.2.4.5 Eb—ODU communication abnormal of main board and display board

Cause: 1. The communication wire damaged.

2. Outdoor main board damaged

3. Display board damaged.

Solution: 1. Replace the communication wire.

2. Replace the outdoor main board.

3. Replace the display board.

3.2.4.6 EC—Communication Error btw ODU PCB MCU and Fan motor / Compressor driving IC

Cause: The ODU mainboard damaged

Solution: Replace the ODU PCB.

3.2.4.7 EE—ODU EEPROM failure.

Cause: The ODU mainboard damaged.

Solution: Replace the ODU PCB.

3.2.4.8 EF---ODU DC fan motor failure

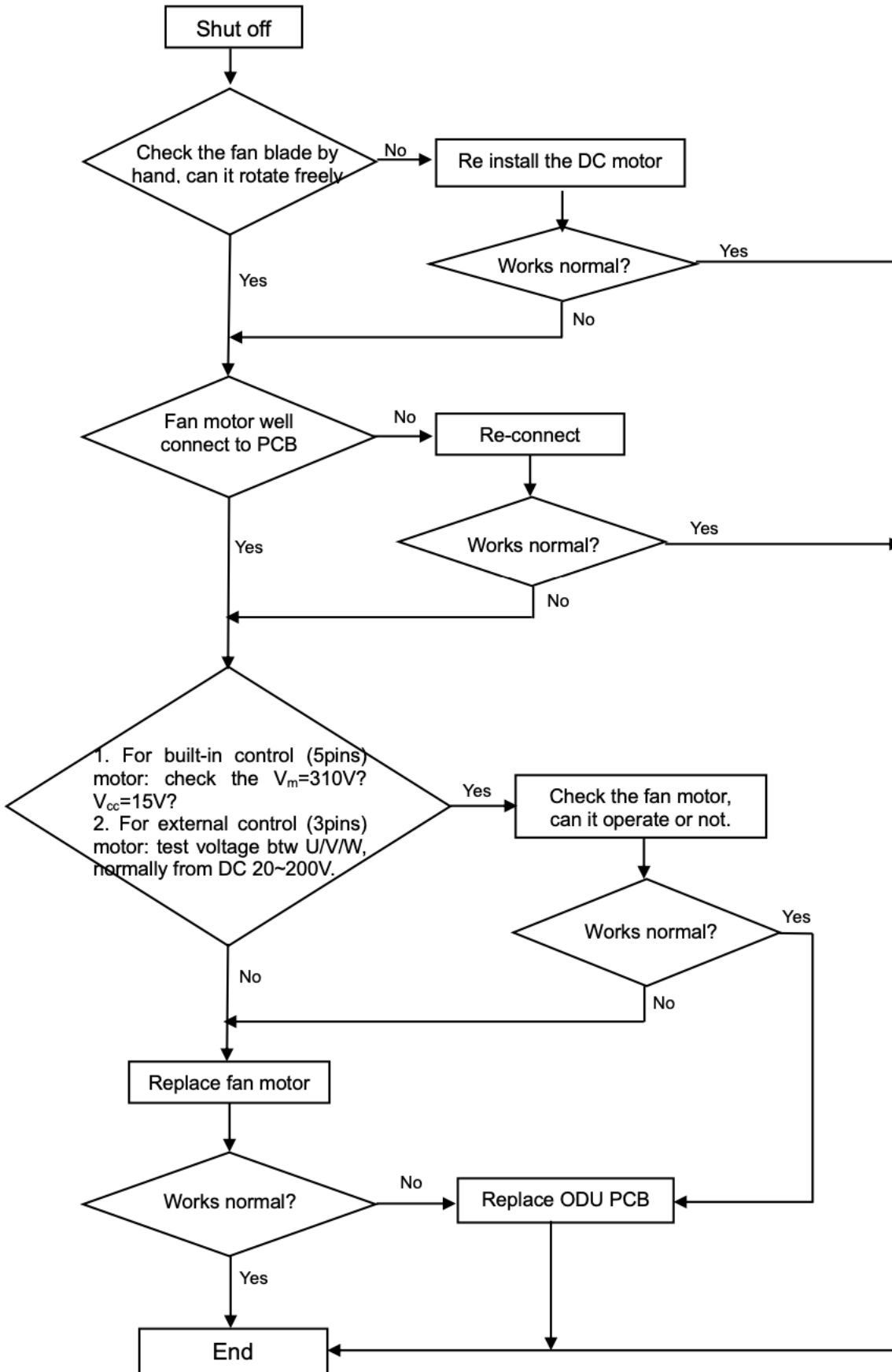

3.2.4.9 EU---ODU voltage test sensor failure

After power relay works, while tested voltage effective value less than 50V for 3s continuously, unit will display EU.

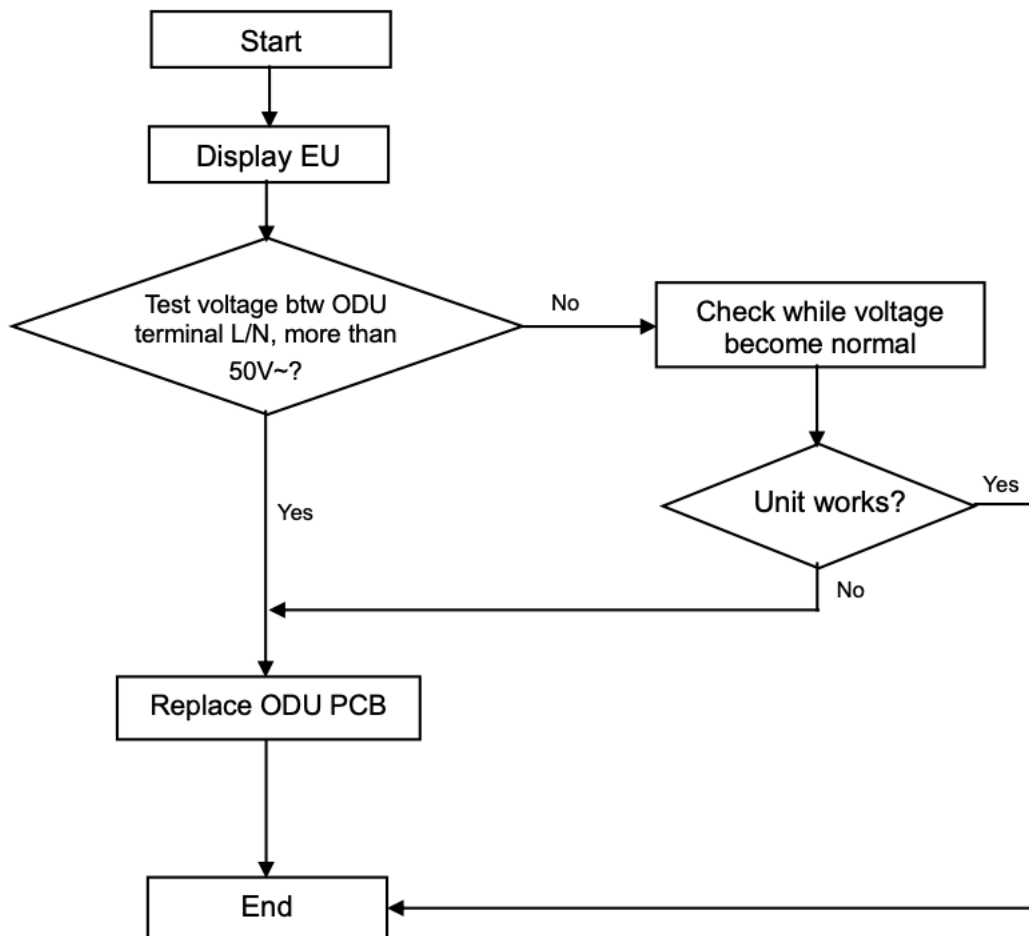

3.2.4.10 P0---IPM protection

When overheat or overcurrent for IPM, AC unit will display P0 protection.

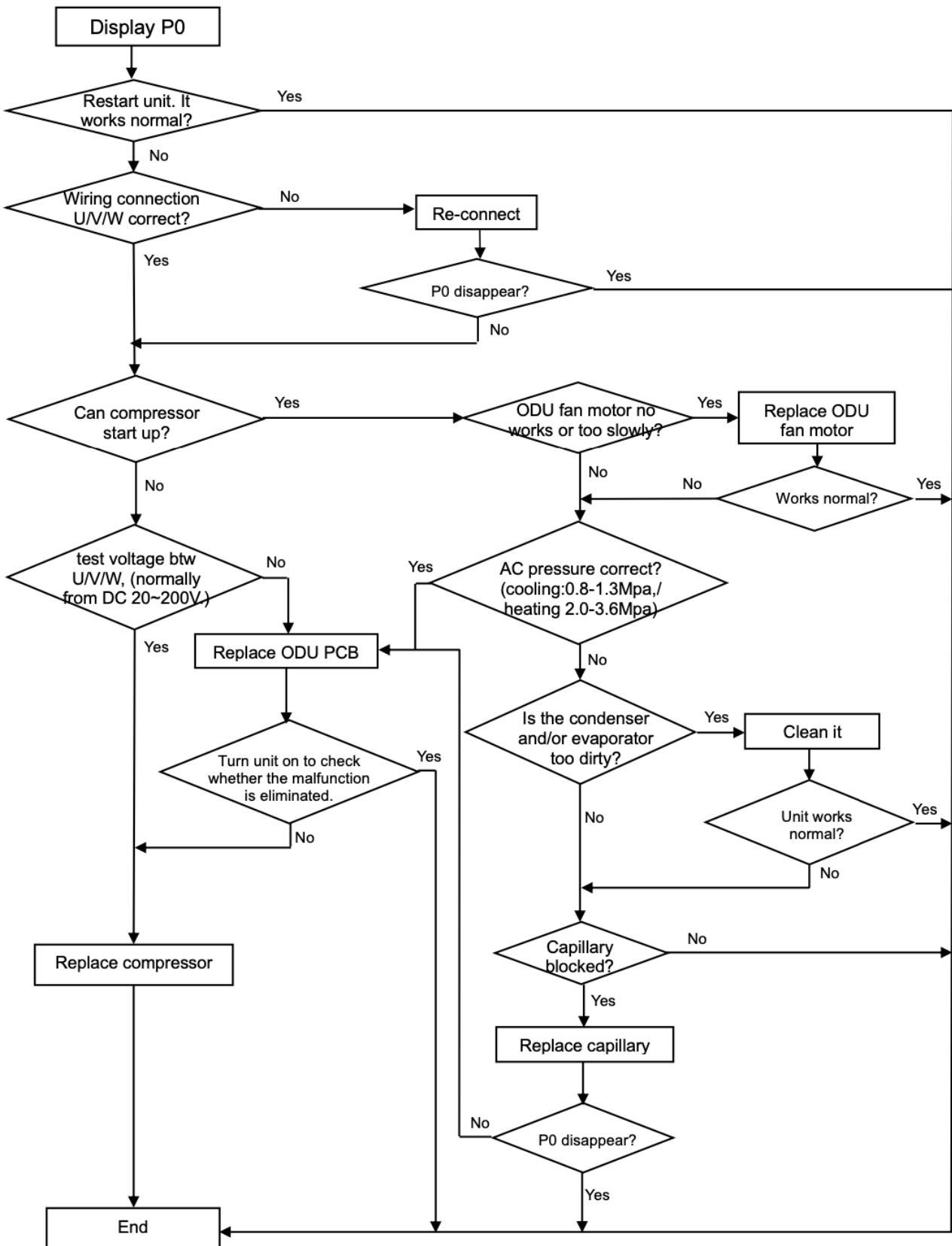

3.2.4.11 P1--- Over / under voltage protection

1. Test voltage between L1 & L2, When the power supply $V > AC260V$ or $V < AC150V$, AC will display P1 protection, unit will recover back to previous status while $V > AC155V$.
2. Test voltage on the big size electrolytic capacitor of ODU PCB, When DC busbar voltage $V > DC420V$ or $V < DC150V$, IDU display P1 protection. unit will recover back to previous status while $DC190V < V < DC410V$

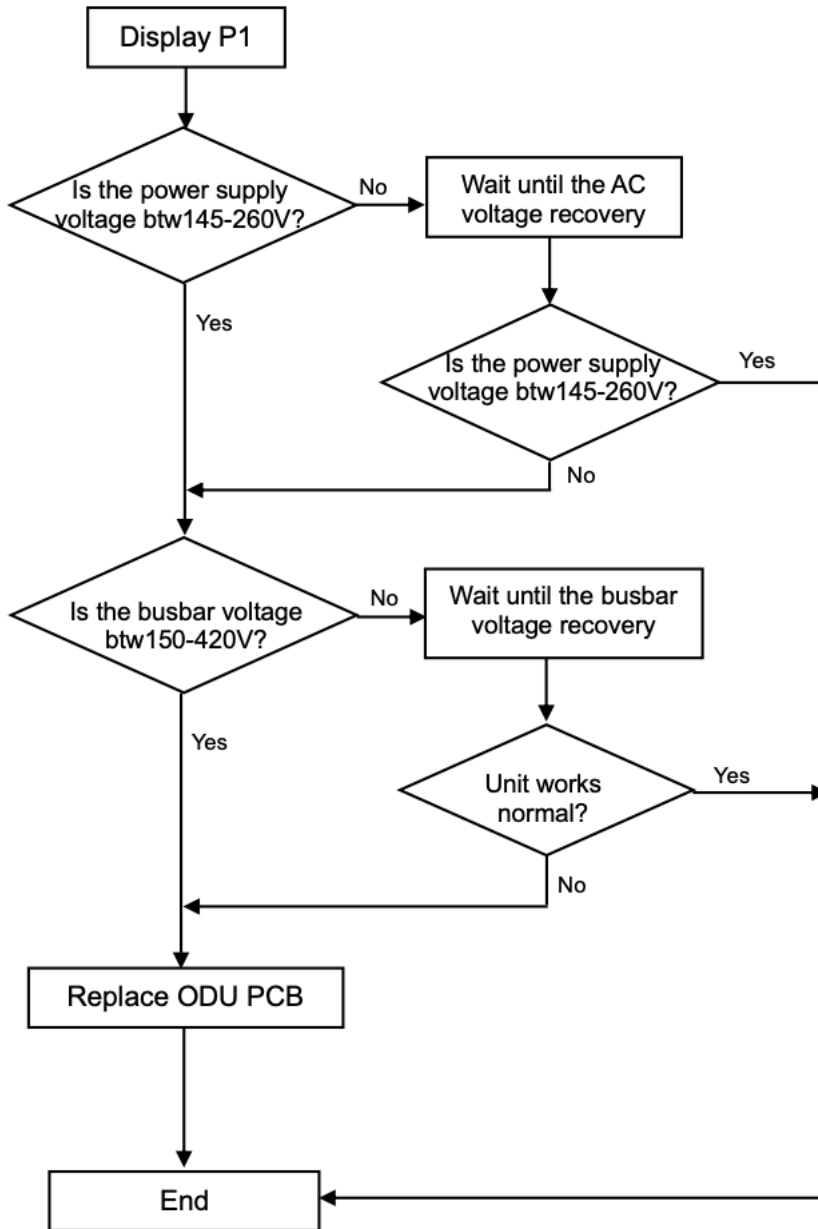

3.2.4.12 P2---Over Current protection

When the AC unit running current more than I_{max} , it will stop and display P2 protection.

Note: for different AC model, I_{max} has a difference valve.

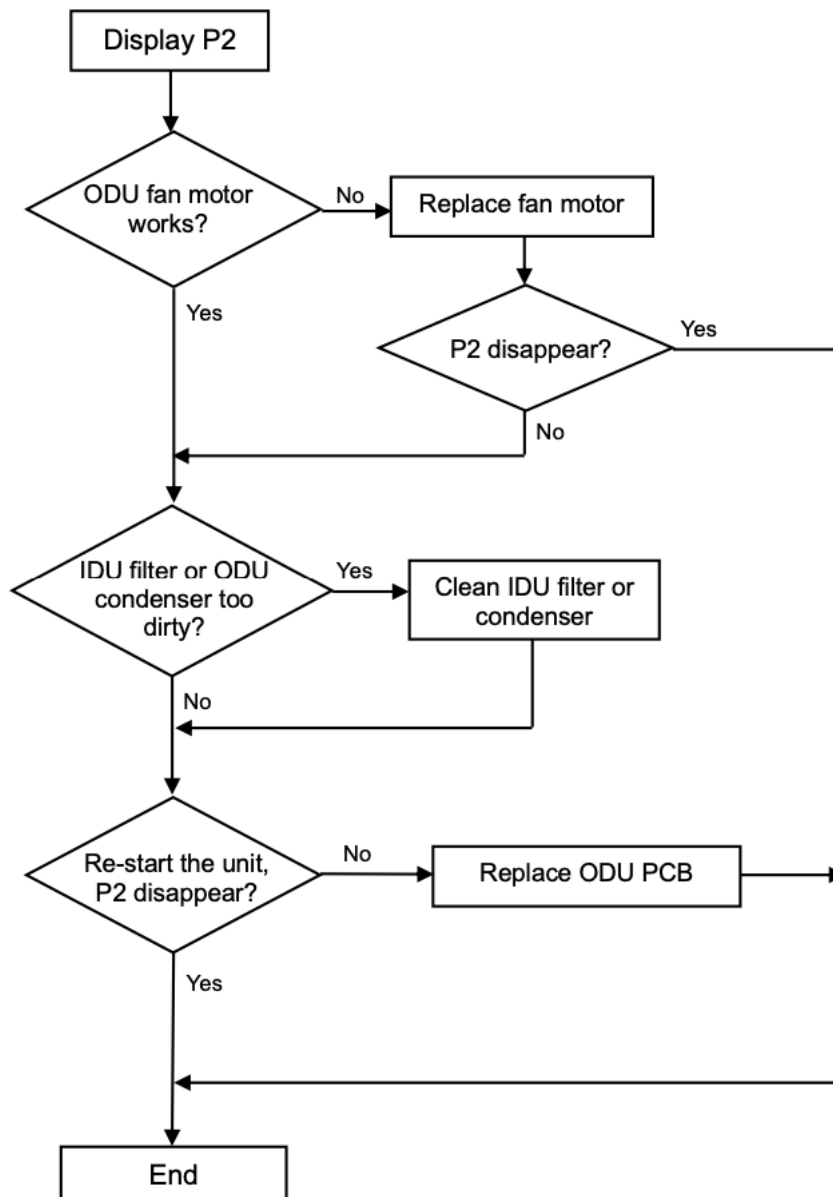

3.2.4.13 P4 ---ODU Discharge temperature overheating protection

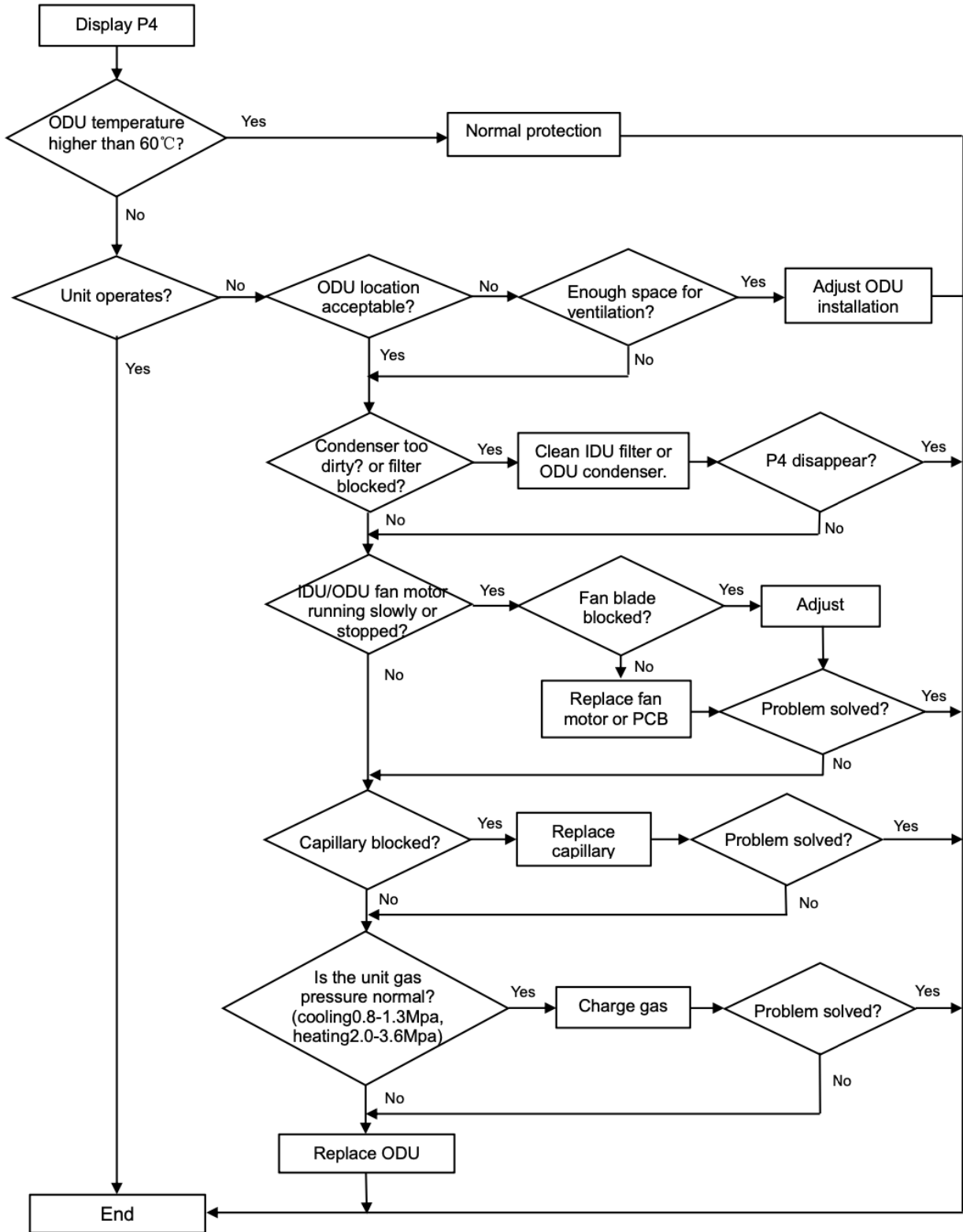

3.2.4.14 P5---Sub-cooling protection on Cooling/Dry mode

On Cooling or Dry mode, when IDU evaporator coil temperature $IPT < 11^{\circ}\text{C}$ / $IPT < 34^{\circ}\text{F}$ continuously for 3 min after compressor start up for 6 min, CPU will switch off outdoor unit and show P5 failure code.

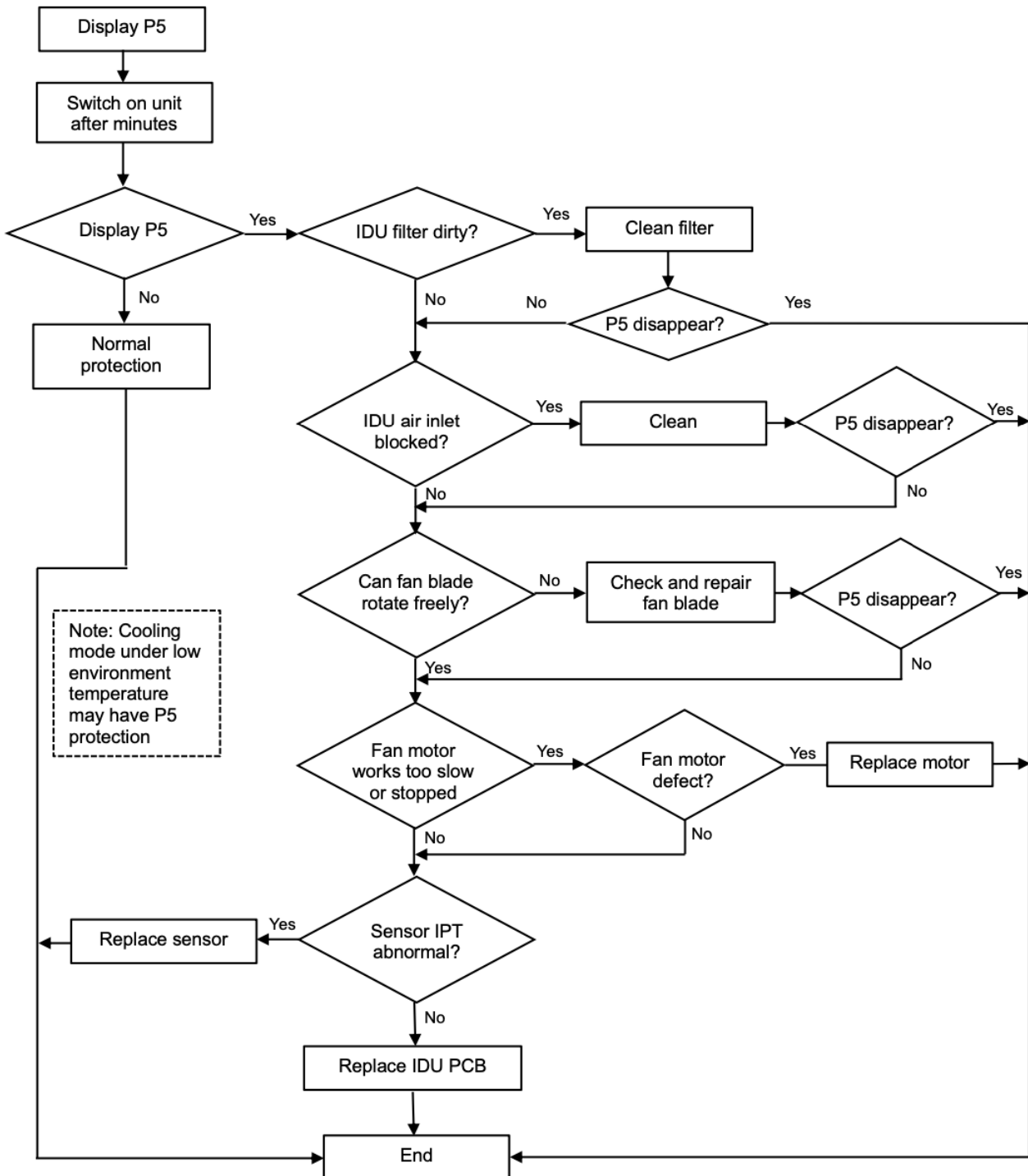

3.2.4.15 P6---Overheating protection on Cooling mode

On Cooling or Dry mode, when ODU condenser coil temperature $OPT \geq 62^\circ$ / $OPT > 144^\circ$ FC , MCU will switch off outdoor unit and show P6 failure code.

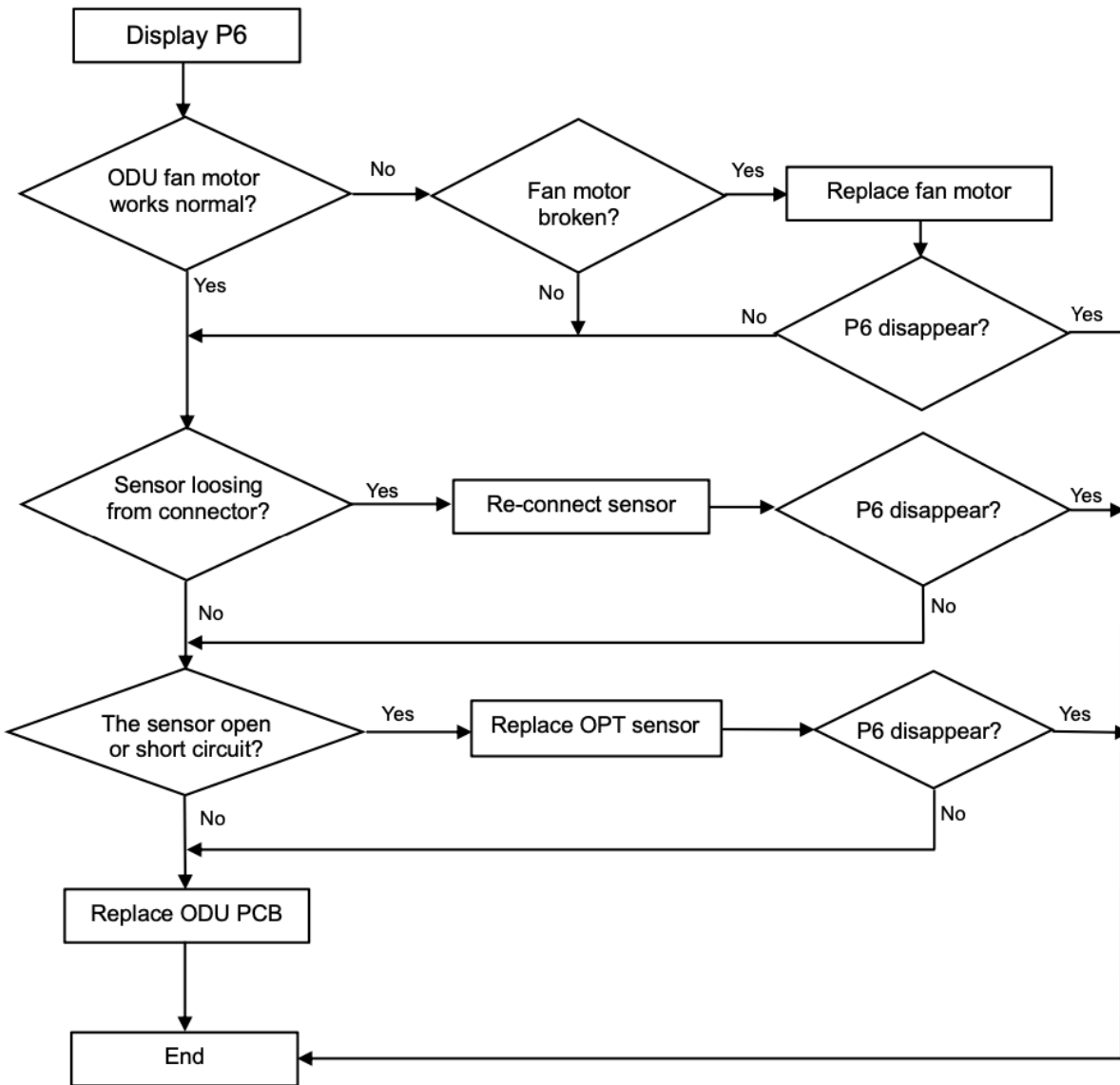

3.2.4.16 P7---Overheating protection on Heating mode

On heating mode, when IDU evaporator coil temperature $IPT \geq 62^{\circ}\text{C}$ / $IPT > 144^{\circ}\text{F}$, IDU PCB will switch off outdoor unit and show P7 failure code.

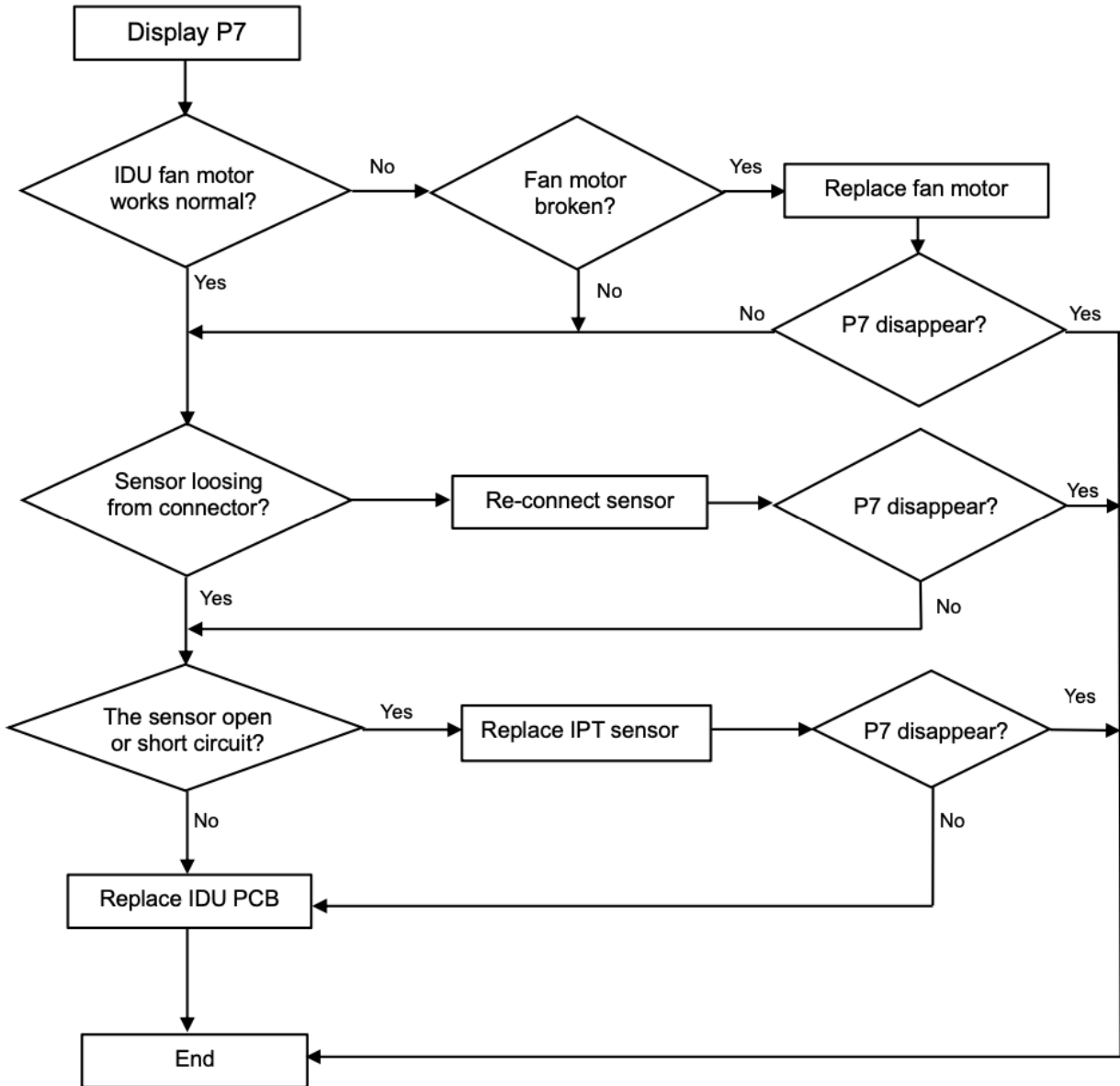

3.2.4.17 P8---Outdoor Overtemperature/Under-temperature protection

When environment temperature as below condition, the compressor will stop working, after 200s delay, the IDU will show P8 failure code.

(1). **On Cooling or Dry mode:** ODU ambient temperature: $OAT < -20^{\circ}C / OAT < -4^{\circ}F$ or $OAT > 63^{\circ}C / OAT > 145^{\circ}F$;

(2). **On Heating mode:**

a. $OAT \geq 40^{\circ}C / OAT > 104^{\circ}F$

b. $30^{\circ}C < OAT \leq 40^{\circ}C$ and $RT > 35^{\circ}C / 86^{\circ}F < OAT \leq 104^{\circ}F$ and $RT > 95^{\circ}F$

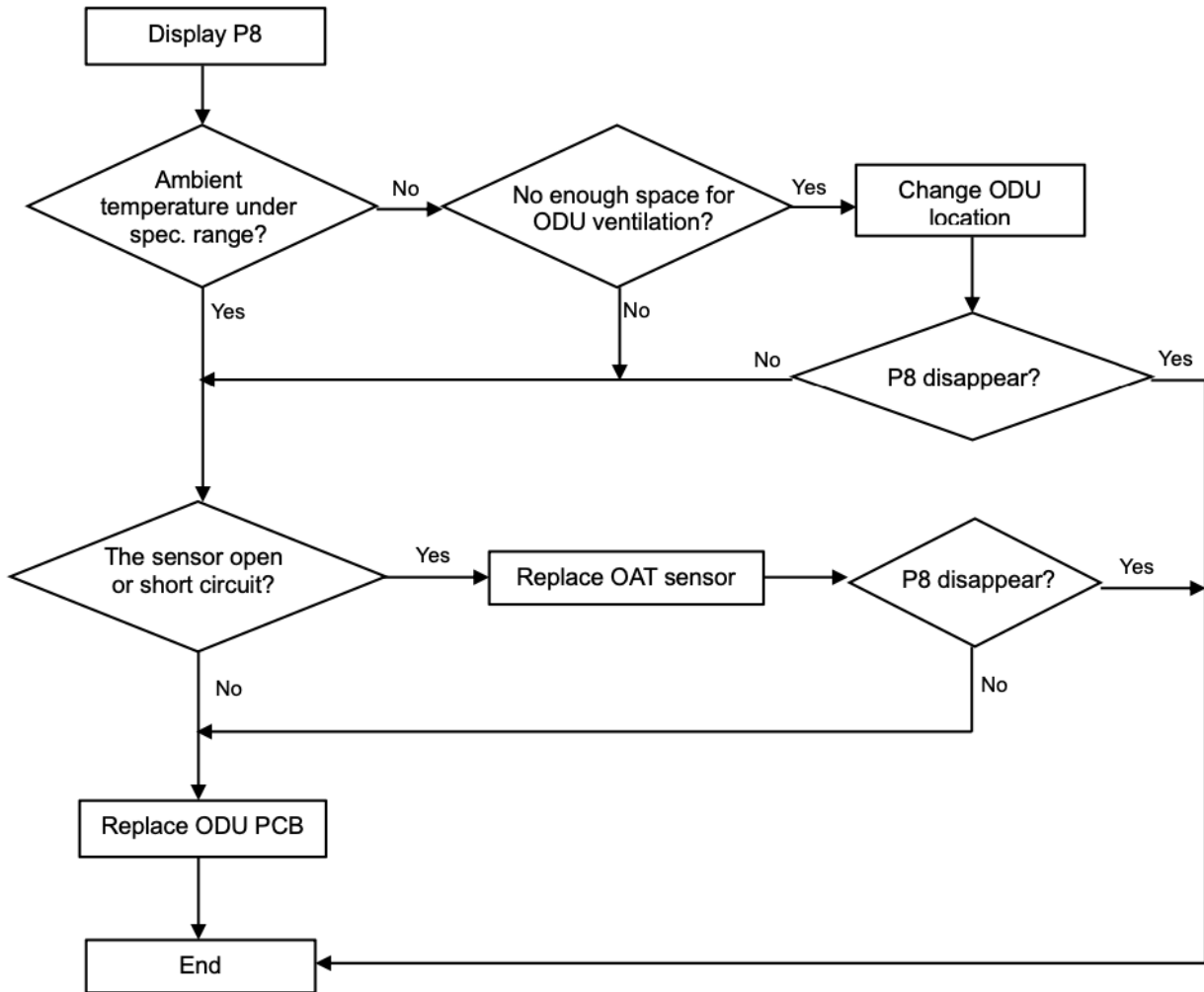

3.2.4.18 P9---The compressor driving protection (the compressor load abnormal)

When compressor start up or in the process of operation, if:

- (1). MCU can't test the feedback signal from compressor, or
- (2). Tested an abnormal signal from compressor, or
- (3). The compressor startup abnormal.

The outdoor unit will shut off, and show P9 protection.

(The unit will re-startup 6 times continuously, if it still can't work normal, then show P9 code)

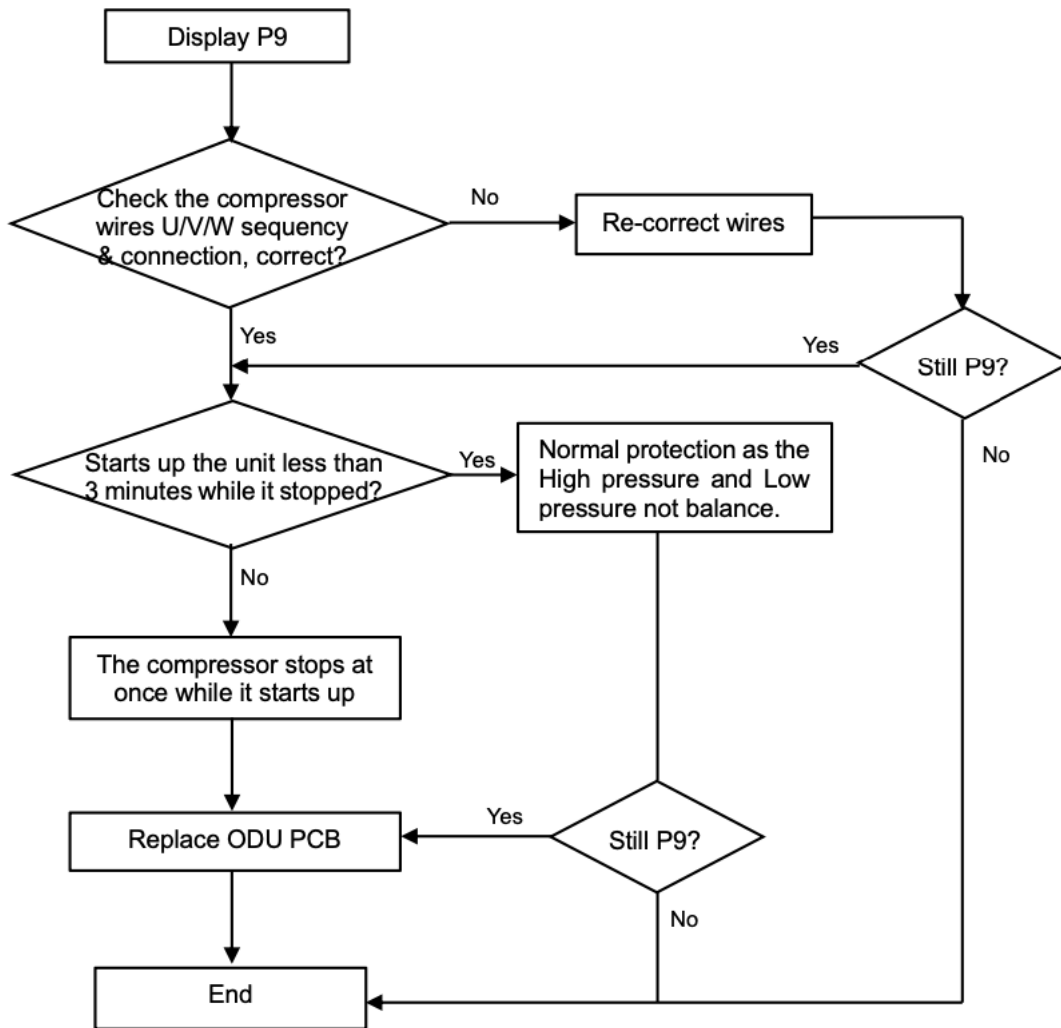

3.2.4.19 F4---Cooling system Gas flow abnormal protection

When compressor startup, unit will check the variation of IDU coil temperature. If there is mistake installer forgetting to open the 2-way or 3-way valve on ODU, the gas can't flow in the cooling system, it will show F4 protection.

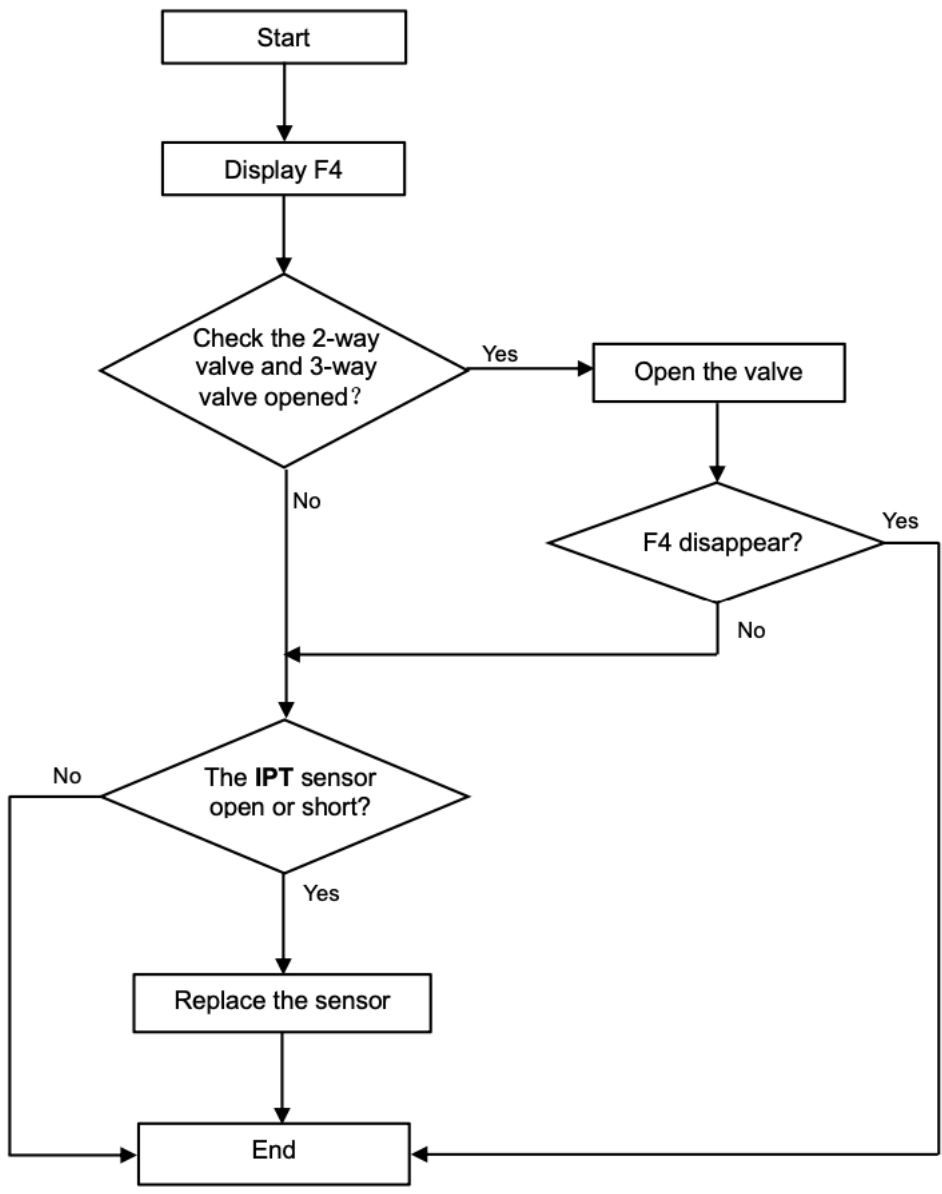

3.2.4.20 F5---PFC Protection

PFC Overcurrent protection

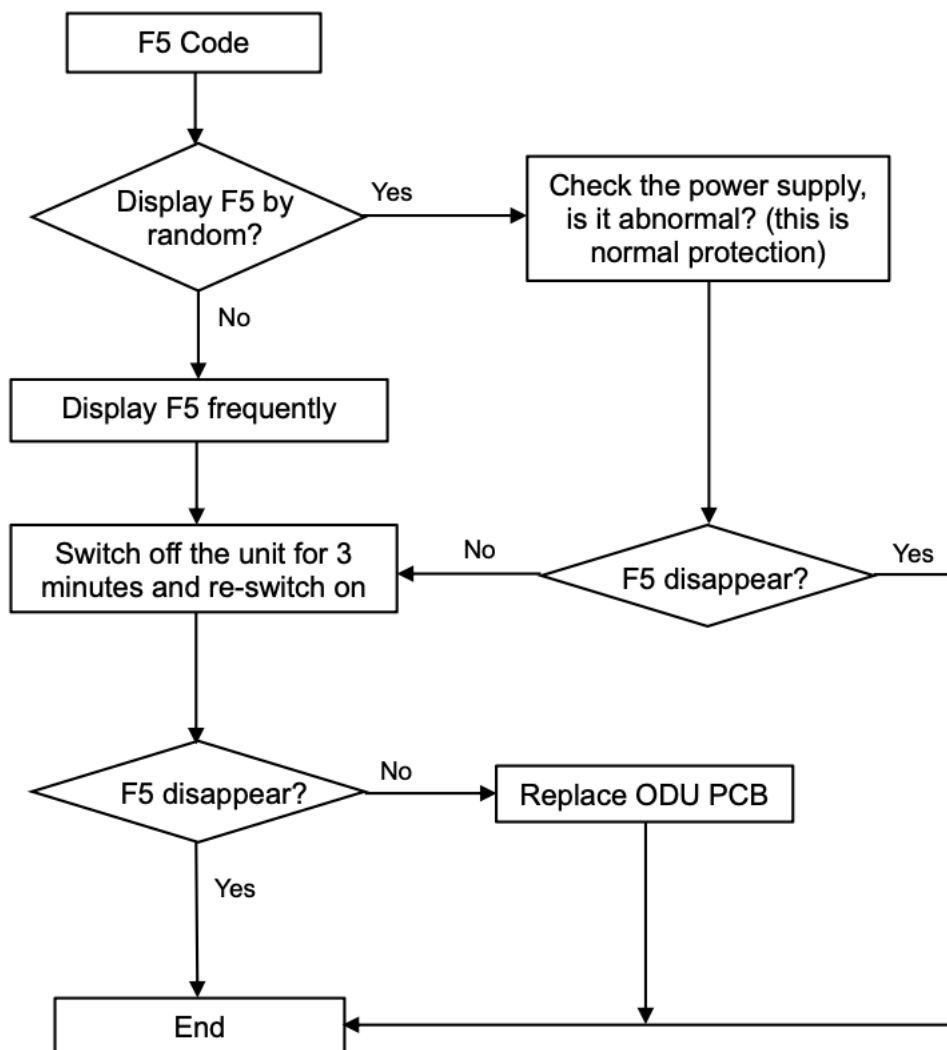

3.2.4.21 F6---The Compressor Lack of phase / Anti-phase protection.

If ODU PCB can't test one, two or even three phases of compressor current, it will show F6 protection.

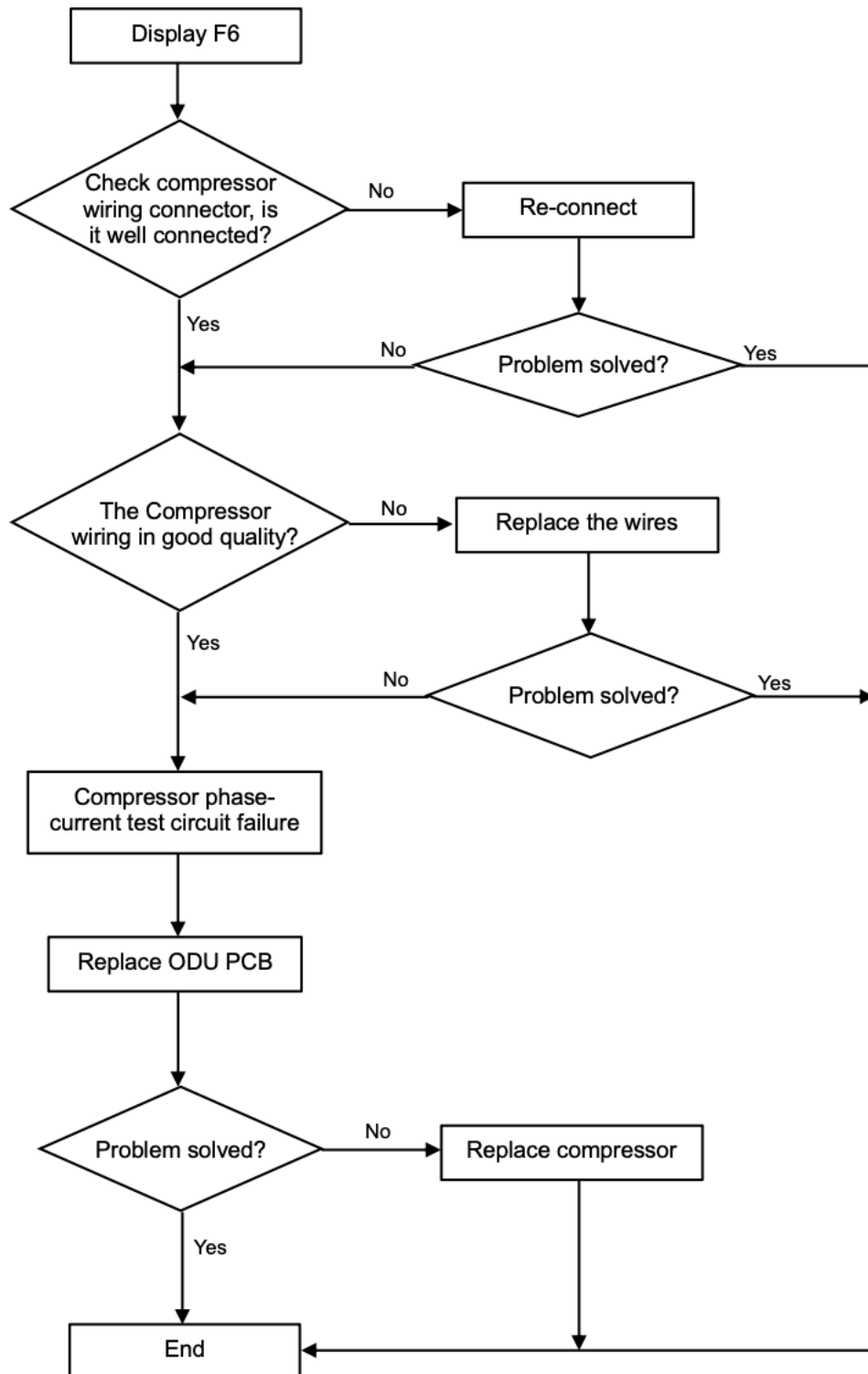

3.2.4.22 F7---Module temperature protection.

IPM overtemperature protection, when IPM temperature more than 95°C, it will show F7.

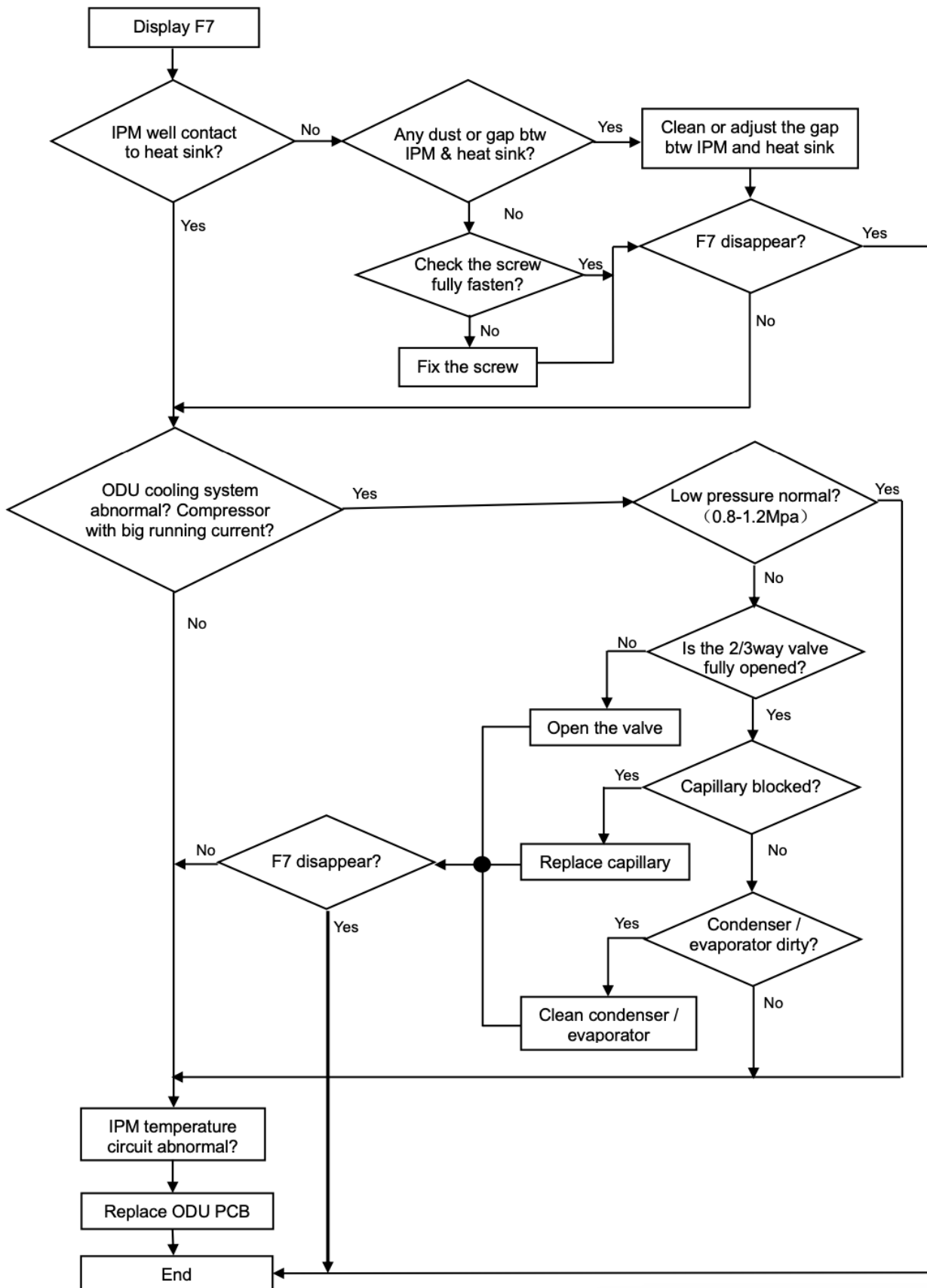

3.2.4.23 F8---4-Way Value Reversing abnormal

On heating mode, if IDU Coil temperature tested lower than Room temperature 5°C or even more after compressor works for 8min, unit will show F8 code.

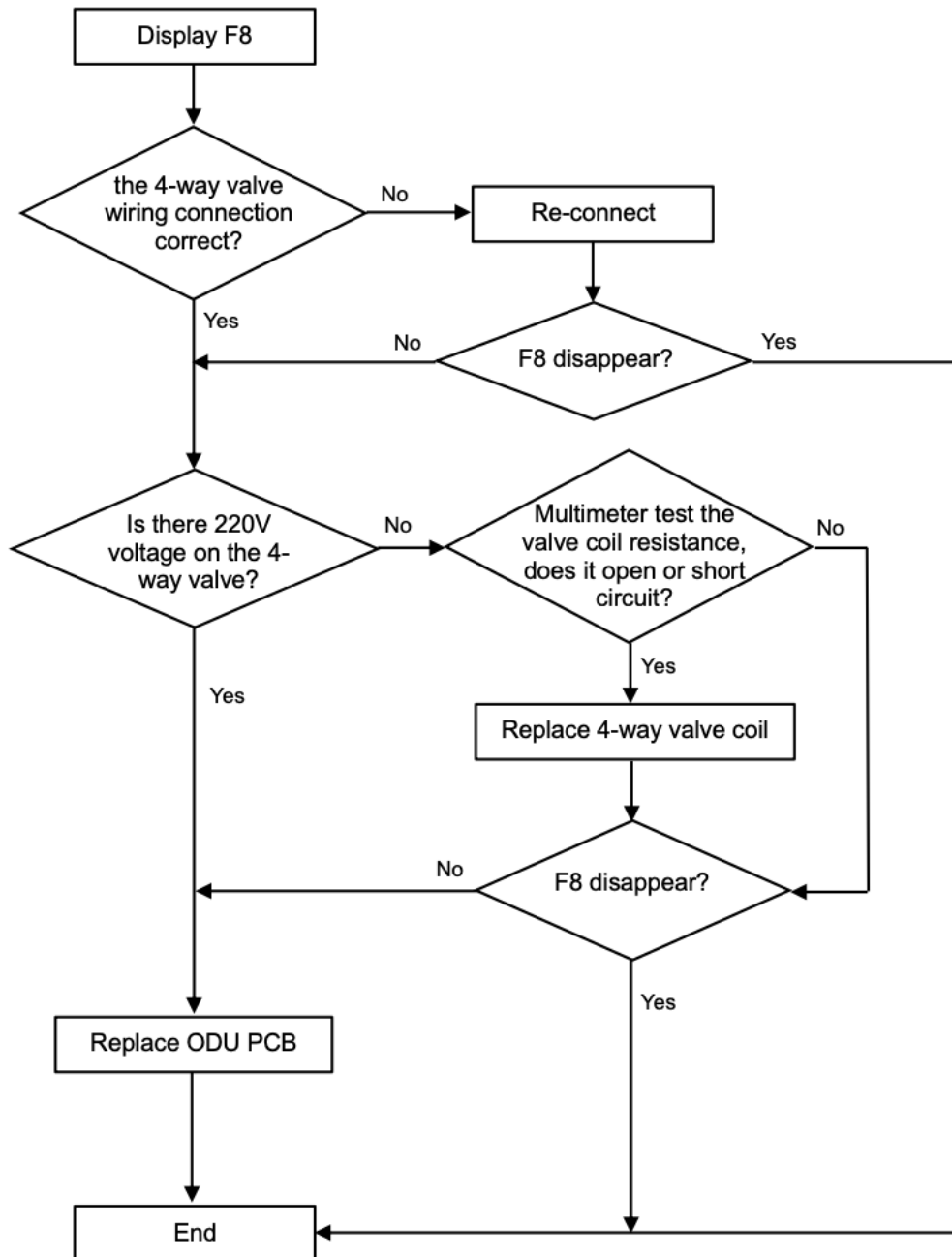

3.2.4.24 F9—The module temperature test circuit failure

Reason: The IPM module temperature test circuit failure.

Solution: Replace the ODU PCB.

3.2.4.25 FA—The compressor Phase-current test circuit failure

Reason: The IPM module temperature test circuit failure.

Solution: Replace the ODU PCB.

3.2.4.26 Fy--- Gas leakage protection

After compressor works in high frequency for 9 min, if the temperature on IDU evaporator & ODU condenser has only a little variation comparing previous, but, the compressor discharge temperature on high level, then the unit will show Fy failure code.

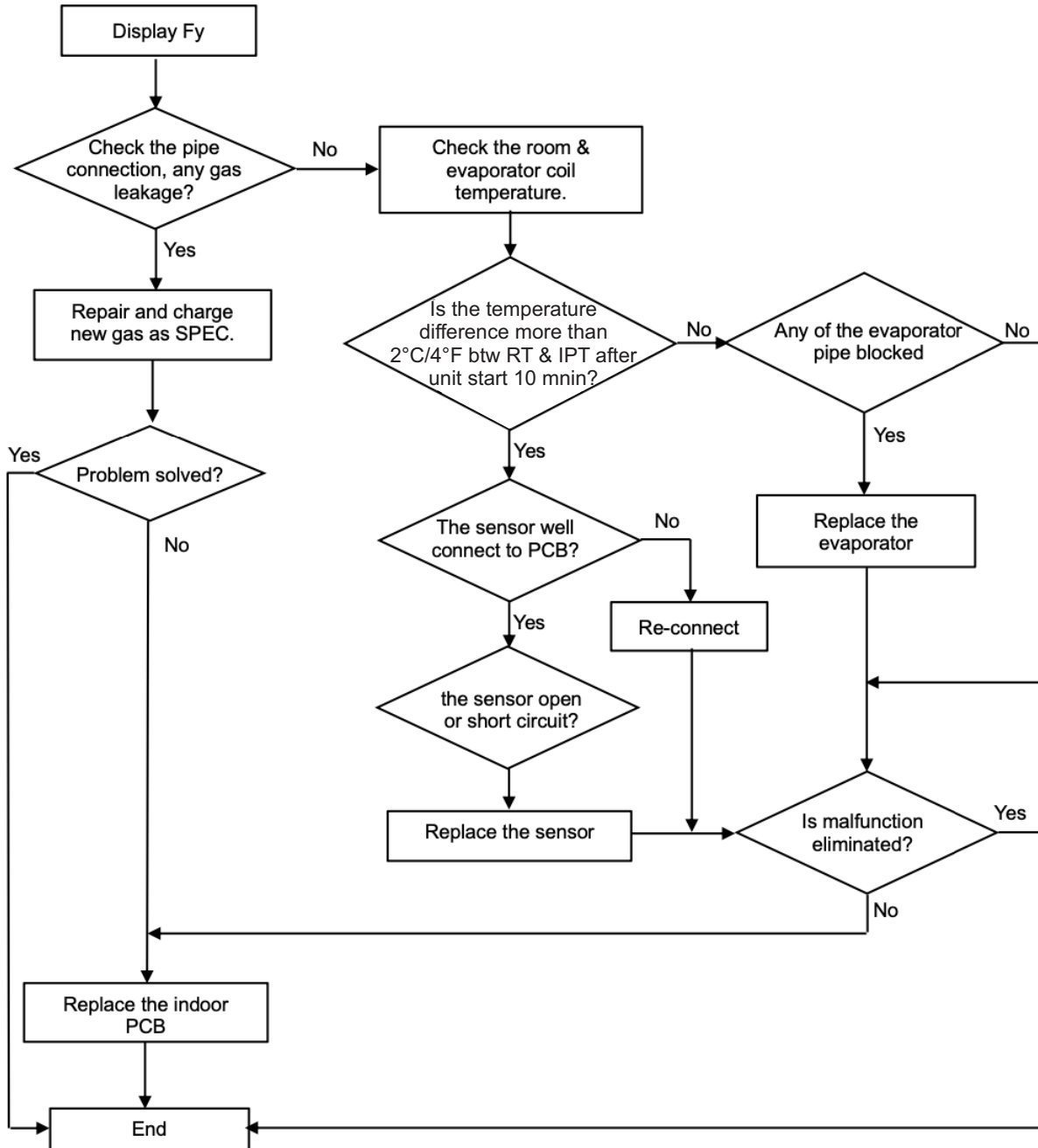

3.2.4.27 H1,H2,H3 & H4 — High pressure/Low pressure switch, Pressure sensor test abnormal.

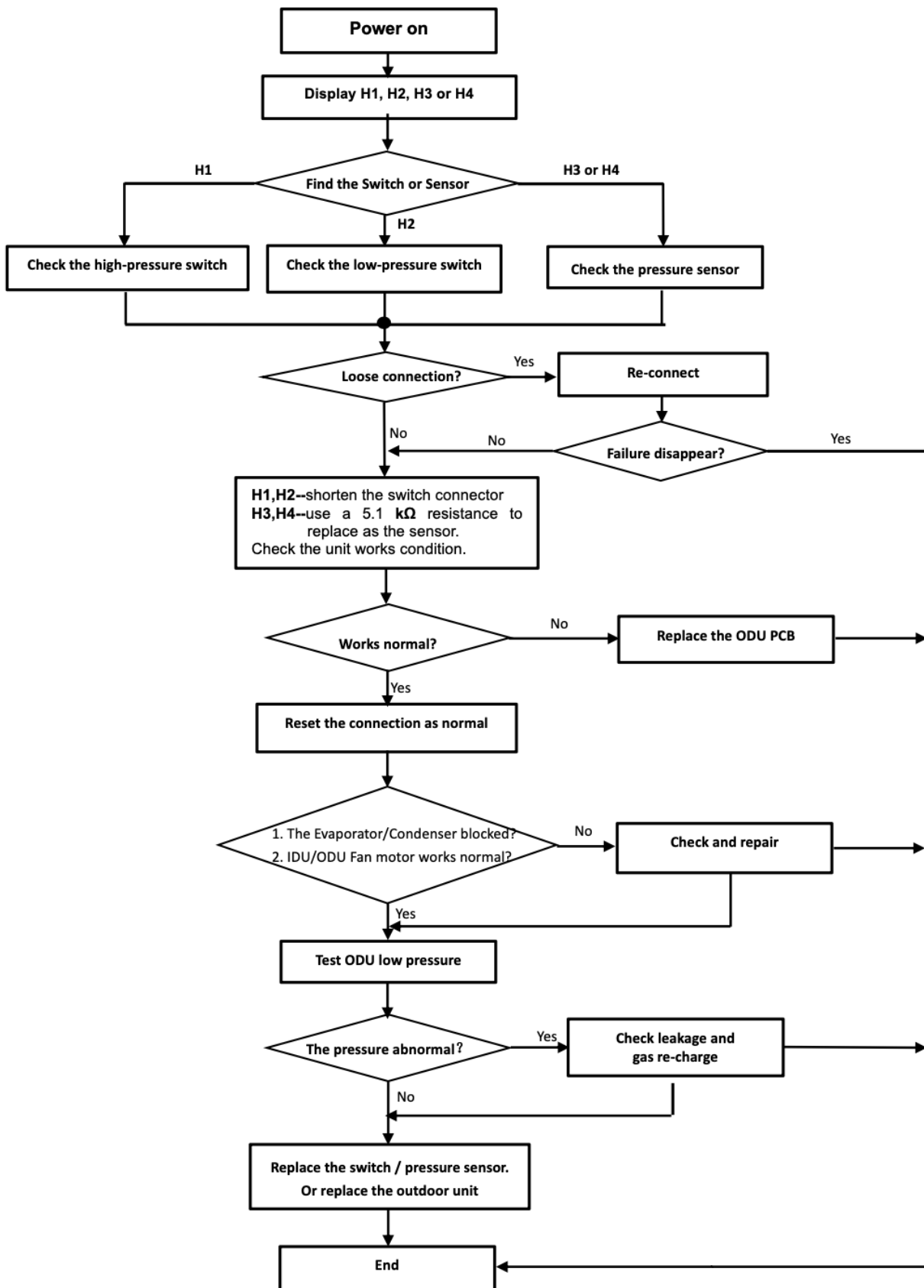

3.2.4.28 Fd — The communication of refrigerant detection sensor and indoor PCB abnormal

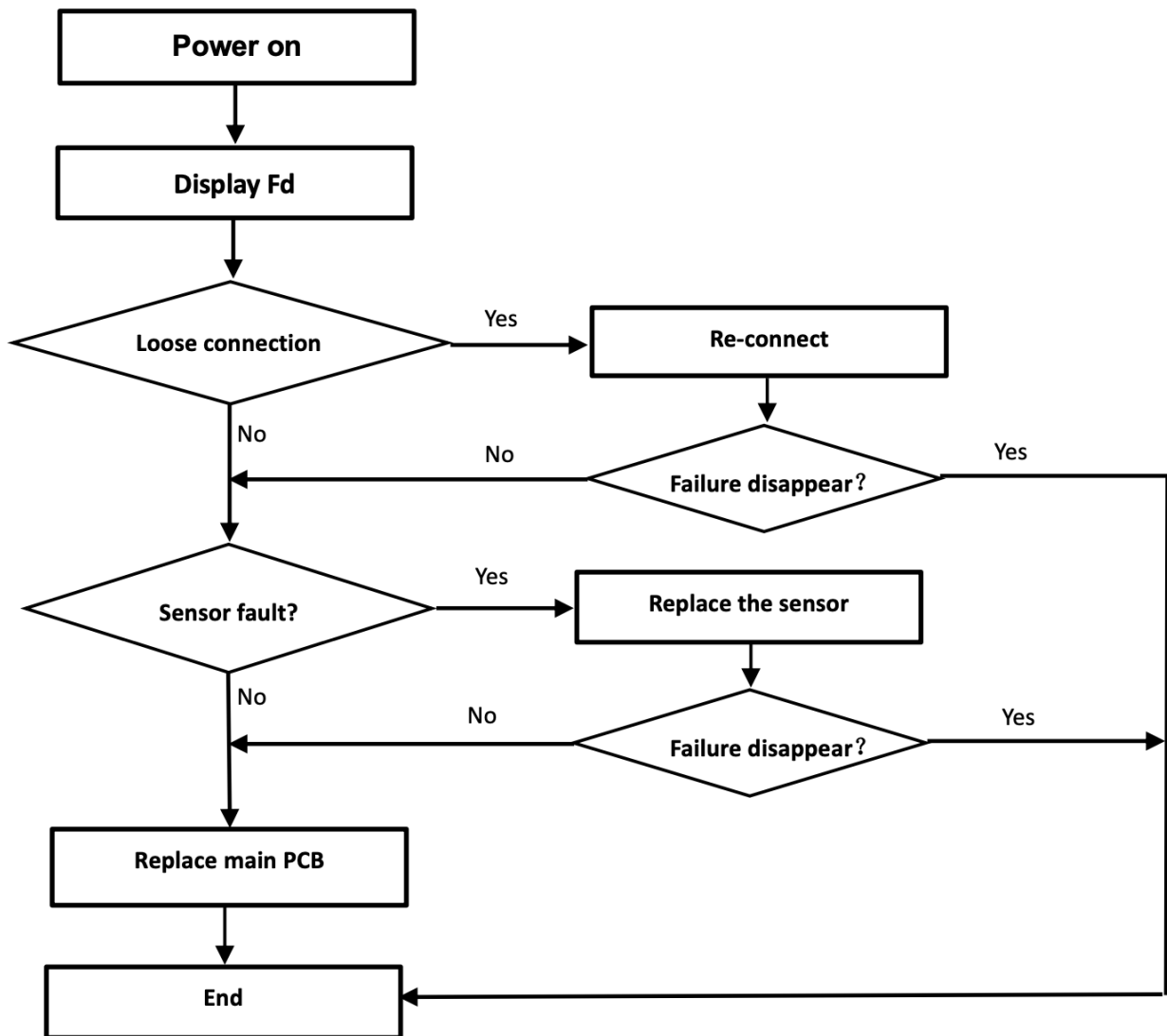

3.2.5 Failures Not Caused by Errors

The following symptoms are not a malfunction and no need repairing.

Problem	Possible Cause
Abnormal noises of outdoor unit	The unit will make different sounds based on its current operating mode.
Both the indoor and outdoor units make noises	The air conditioner may hum during operation. This is a normal phenomenon, which is caused by refrigerant gas flowing through the indoor and outdoor units.
	When the air conditioner is turned on, and just stopped or defrosted, a hiss may be heard. This noise is normal and is caused by refrigerant gas stopping or turning.
Unit does not turn on when pressing ON/ OFF button	The unit has a 3-minute protection feature that prevents the unit from overloading. The unit cannot be restarted within three minutes of being turned off.
	Cooling and Heating Models: If the Operation light and PRE-DEF (Pre-heating/ Defrost) indicators are lit up, the outdoor temperature is too cold and the unit's anti-cold wind is activated in order to defrost the unit.
The unit changes from COOL mode to FAN mode	The unit changes its setting to prevent frost from forming on the unit. Once the temperature increases, the unit will start operating again.
	The set temperature has been reached, at which point the unit turns off the compressor. The unit will resume operating when the temperature fluctuates again.
Both the indoor and outdoor units emit white mist	When the unit restarts in HEAT mode after defrosting, white mist may be emitted due to moisture generated from the defrosting process.
Dust is emitted from either the indoor or outdoor unit	The unit may accumulate dust during extended periods of nonuse, which will be emitted when the unit is turned on. This can be mitigated by covering the unit during long periods of inactivity.
The unit emits a bad odor	The unit may absorb odors from the environment (such as furniture, cooking, cigarettes, etc.) which will be emitted during operations.
	The unit filters have become moldy and should be cleaned.
The fan of the outdoor unit does not operate	During operation, the fan speed is controlled to optimize product operation.

3.3 Maintenance

3.3.1 System diagram

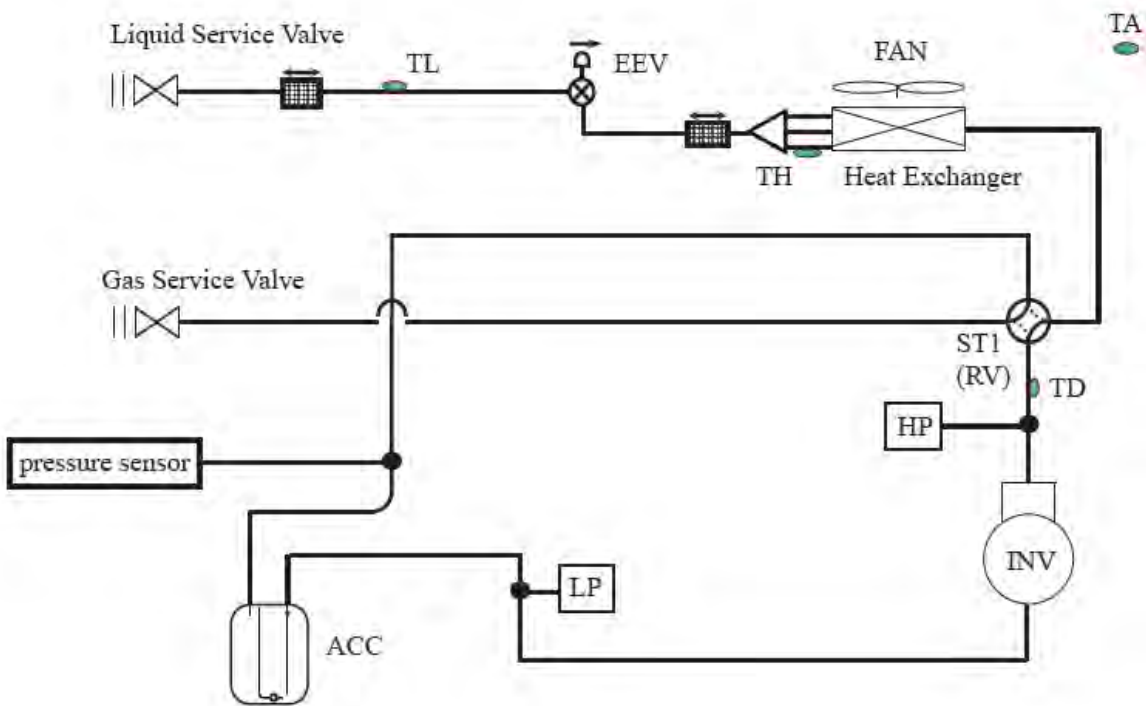

Name	Symbol	Function
Inverter compressor	INV	Adjusts refrigerant flow rate by changing the speed (RPS) based on objective pressure.
DC motor	FAN	Outputs heat exchanger capacity by adjusting the motor rotation speed based on operating pressure.
Electronic expansion valve	EEV	Fully open in cooling mode and defrost operation. Control compressor discharge superheat in heating mode.
Reversing valve	ST1 (RV)	Switches the operation mode between heating and cooling (including defrost control).
Temperature sensor	TH	Uses to control defrost during heating operation.
	TA	Uses to detect outdoor air temperature and control fan speed.
	TL	Uses to detect liquid line temperature and calculate sub-cooling (SC).
	TD	Uses to detect compressor discharge temperature and calculate discharge: superheat (DSH).
	TF	Uses to detect heatsink temperature of inverter module.
High pressure switch	HP	Uses to detect high pressure.
Low pressure switch	LP	Uses to detect low pressure.
Accumulator	ACC	To prevent the compressor from ingesting liquid refrigerant

3.3.2 Connection pipe vacuum pumping

1. Use vacuum Pump

- 1) Air and humidity left inside the refrigerant circuit can cause compressor malfunction. After having connected the indoor and outdoor units, bleed the air and humidity from the refrigerant circuit by using a vacuum pump.
- 2) Open the piezometer and operation for 30-40minutes to check if the pressure of piezometer remains in **-0.1Mpa**.
- 3) Close the vacuum pump and maintain this status for 5-8min to check if the pressure of piezometer remains in **-0.1Mpa**. If the pressure decrease, there may be leakage.
- 4) Remove the piezometer, open the valve core of liquid valve and gas valve completely.
- 5) Tighten the screw caps of valve and refrigerant charging vent.

2. Leakage Detection

- 1). With leakage detection.
Check if there is leakage with leakage detection.
- 2). With soap water. If leakage detection is not available, please use soap water for leakage detection. Apply soap water at the suspected position and keep the soap water for more than 3min. If there are air bubbles coming out of this position, there a leakage.

3.3.3 Refrigerant charging

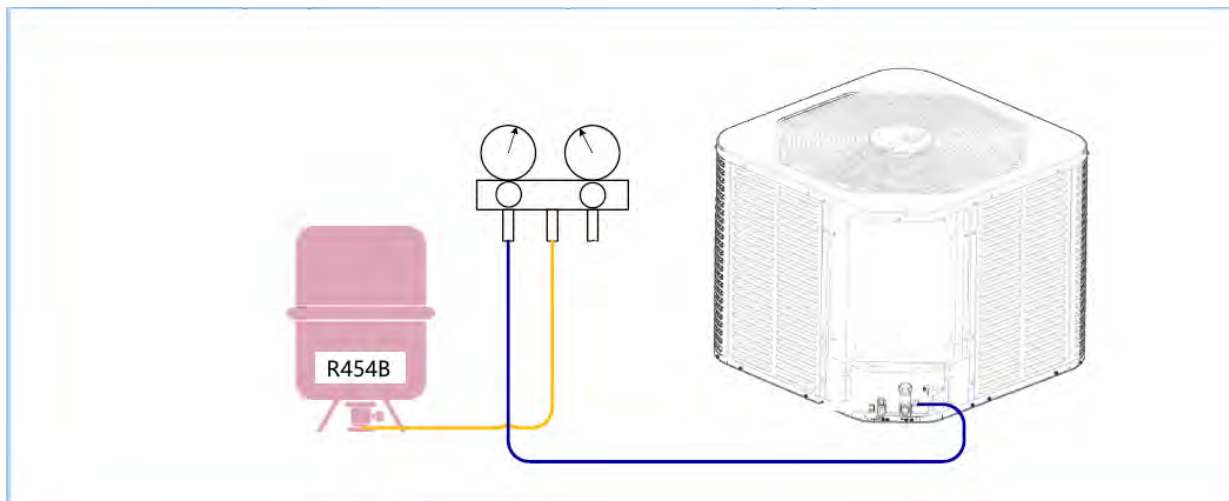

The refrigerant filling volume of the outdoor unit is a standard connecting pipe length of 7.5m./25 ft
If a long connecting pipe is required, refrigerant should be filled additionally. 50g/m / 0.55 oz/ft is added to the unit for cooling by inverting the refrigerant tank and adding refrigerant at the low-pressure shut-off valve.

Pipe Length and Additional Refrigerant

Model	KOIT24H2-41G	KOIT36H2-41G	KOIT48H2-41G	KOIT60H2-41G
Length of pipe with standard charge(ft)	25	25	25	25
Refrigerant capacity of standard charge(bls)	4.74	6.28	8.82	8.82
The longest pipe length(ft)	100	100	165	165
Additional refrigerant charge(bls/ft)	0.0335	0.0335	0.0335	0.0335
Max.diff.in level between indoor and outdoor unit(ft)	50	50	50	50

For example, for a 36K model, when the pipe is 100ft, the additional refrigerant capacity is $(100-25) \times 0.0335 = 2.511$ bs, and the refrigerant capacity of the whole model is $6.28 + 2.51 = 8.79$ lbs.

3.3.4 Maintenance of major components

Indoor unit: control board, centrifugal motor, thermistor, refrigerant leakage sensor, etc.

Outdoor unit: electronic control, axial fan, etc.

Disassembly and assembly can be conducted as instructed below.

3.3.5 Removal of major components

Disassemble of Indoor unit

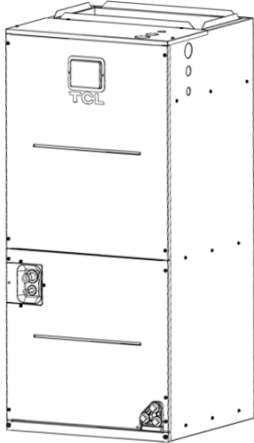
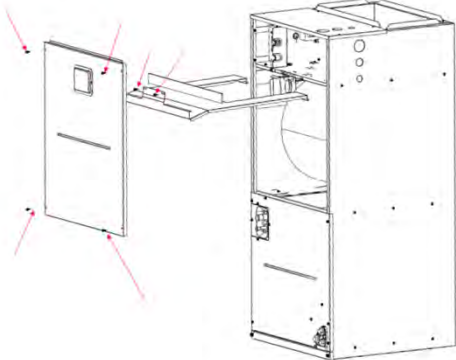
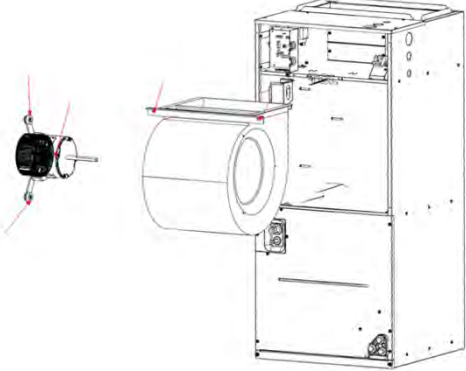
36K inverter top air outlet indoor unit for North America	
Step	2D picture
1. State before disassembly	
State of prototype before disassembly	
2. Disassemble the upper rear side panel and drip tray.	
<p>A. Remove the four screws on the upper rear side panel to remove the upper rear side panel component.</p> <p>B. Remove the two screws on the drip tray to remove it.</p>	
3. Disassemble the blower assembly module and the motor.	
Remove the two screws on the blower assembly module to remove the entire blower module, and then remove the three bolts on the motor to remove the motor from the blower assembly module.	
4. Disassemble the electronic control cover component and internal electronic control module, and remove the control board.	

Remove the four screws on the electronic control cover component to remove the electronic control cover component. Remove the three screws on the internal electrical control module to remove the internal electrical control module, and remove the control board, which is connected to the power mounting panel through a fastener.

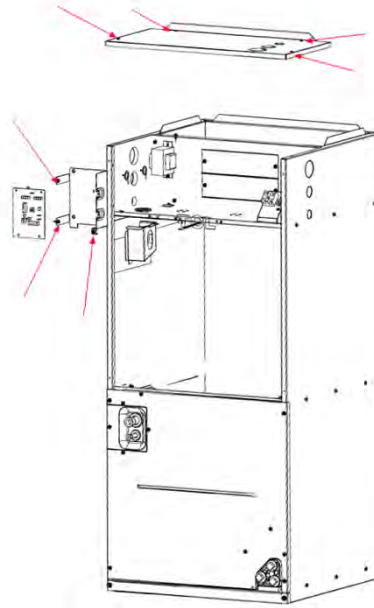

5. Remove the front side panel component and piping cover component.

Remove the nine screws on the front side panel to remove the front side panel, and then remove the one screw on the piping cover plate to remove the piping cover plate.

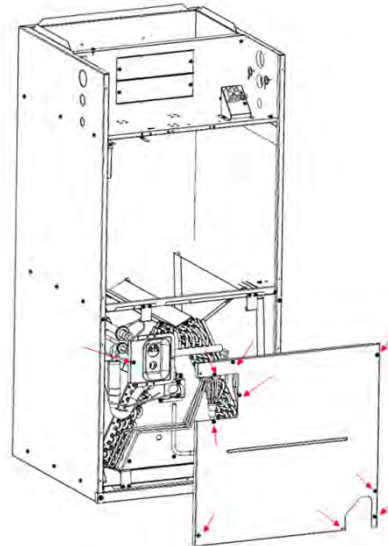

6. Evaporator assembly module

Remove the four screws on the fixing hooks of the two trip trays to remove the two fixing hooks of the trip trays, and draw out the entire evaporator as shown in the picture.

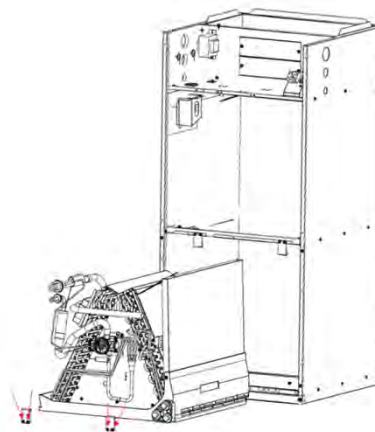

7. Disassemble the refrigerator sensor.

Remove the two screws on both sides of the support bar to remove the support bar, and then remove the one screw on the refrigerant sensor to remove it from the support bar.

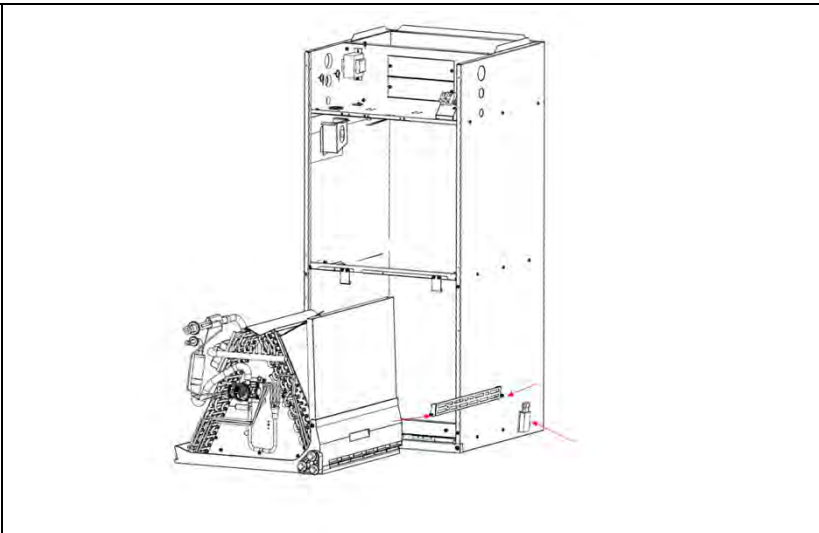

8. Disassemble the electric auxiliary heater.

Remove the four screws on the baffle of the electric auxiliary heater in the direction shown in the picture to remove the electric auxiliary heater.

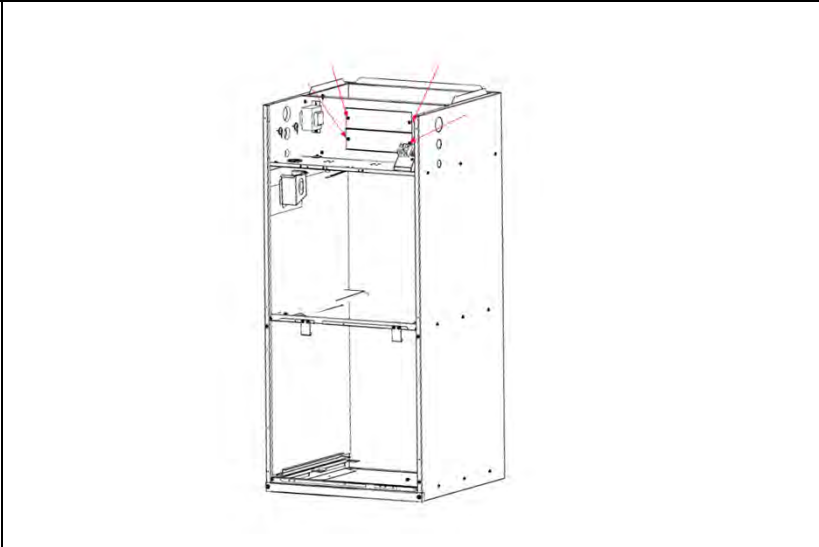

Disassemble of outdoor unit

Step	Detailed steps / pictures
<p>Before disassembly</p>	
<p>Step 1: Remove the top cover component, fan blades, and motor.</p>	

Remove the fixing screws from the top cover component to remove the top cover.

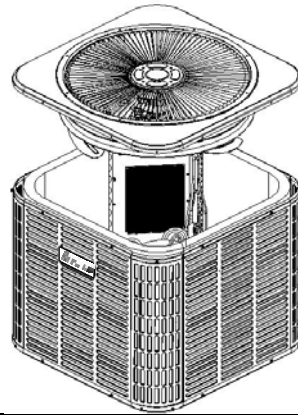

Step 2: Remove the axial flow fan blades and motor.

1) Remove the fixing screws of the axial flow fan blades to remove the axial flow fan blades.

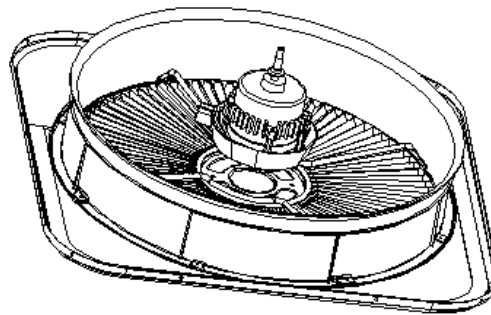
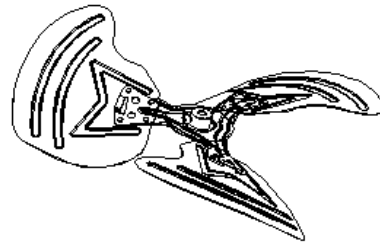

2) Remove the fixing screw of the motor to remove the motor.

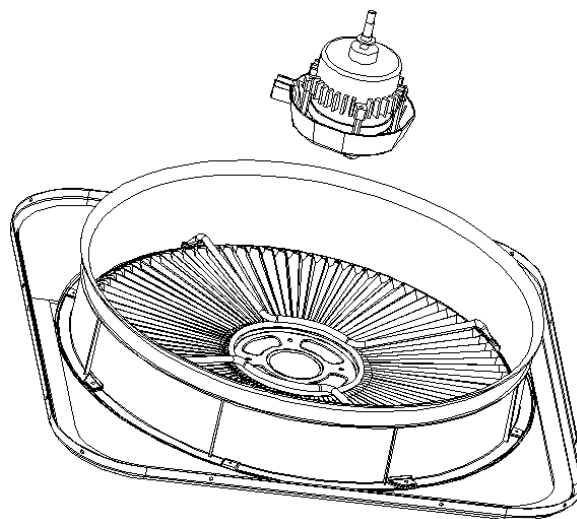

Step 3: Remove the cover plate component of the electric control box and the valve body cover plate.

Remove the fixing screws of the electric control box cover component to remove the electric control box cover.

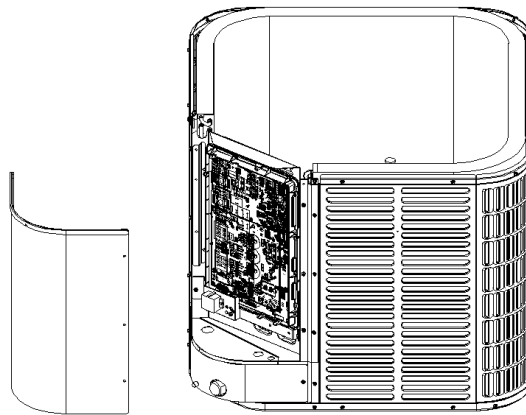

Remove the fixing screws of the valve body cover plate to remove the valve body cover plate.

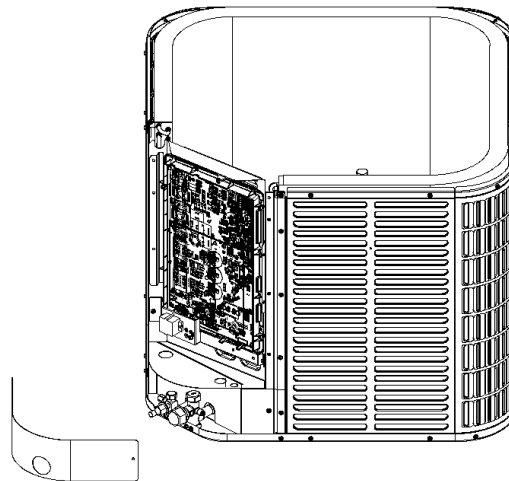

Step 4: Remove side panel 1.

Remove the fixing screws of the side panel to remove side panel 1.

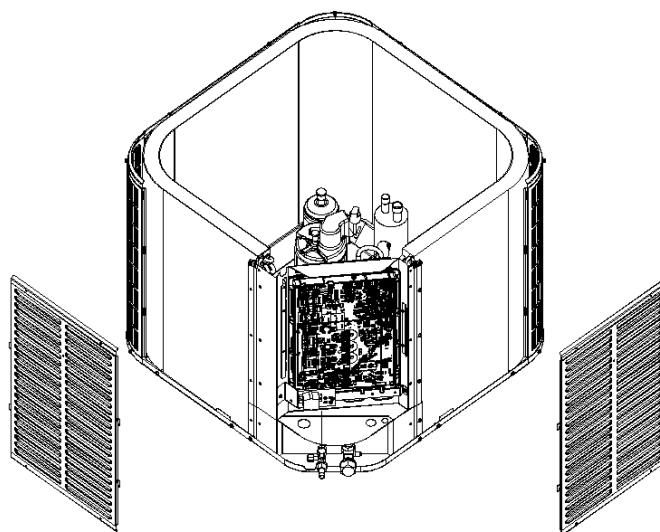

Step 5: Remove the electrical box component.

Remove the fixing screws of the electrical control box component, loosen the cable tie, and unplug the plug to remove the electrical control box.

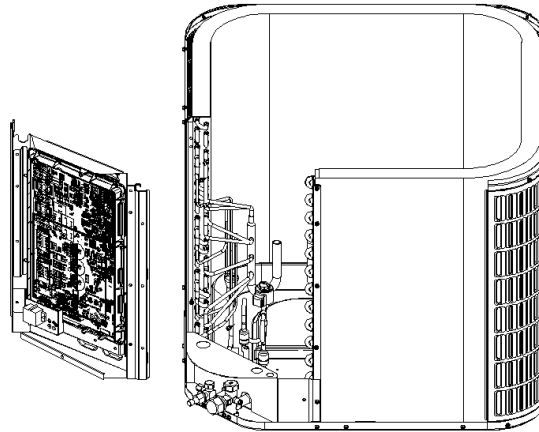

Step 6: Remove the terminal bracket.

Remove the fixing screws of the terminal bracket to remove the terminal bracket.

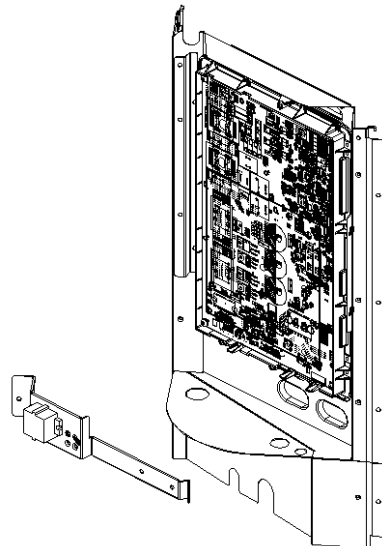

Step 7: Remove the electronic control board.

Remove the fixing screws of the electronic control board to remove the electronic control board.

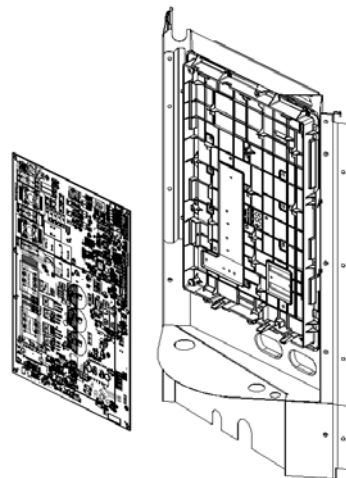

Step 8: Remove the lower side panel.

Remove the fixing screws of the lower side panel to remove the lower side panel.

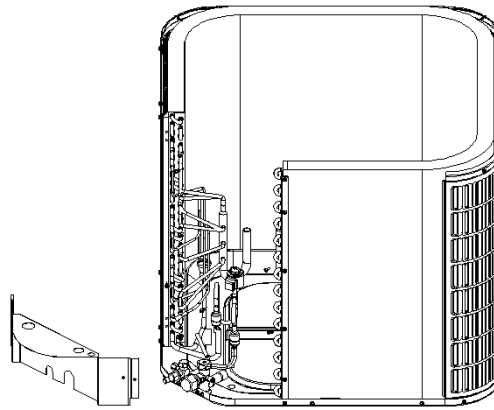

Step 9: Remove the valve.

Remove the valve fixing screws, and then take it out. Before unsoldering, ensure that the refrigerant has been fully discharged. Before unsoldering, fully wrap the valve with damp cloth to prevent high-temperature scalds.

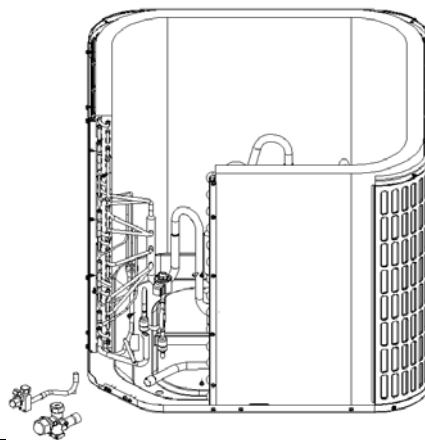

Step 10: Remove the condenser.

Remove the fixing screws at the bottom of the condenser to remove the condenser upwards.

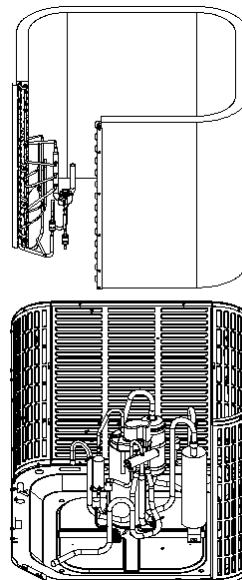

Step 11: Remove the four-way valve component.

Heat the brazing position to loosen the pipeline system. Be careful not to burn out the compressor and nameplate.

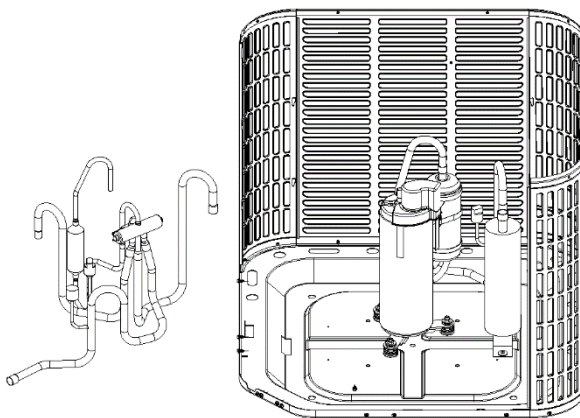

Step 12: Remove the compressor.

Loosen the compressor foot pad bolts to remove the compressor.

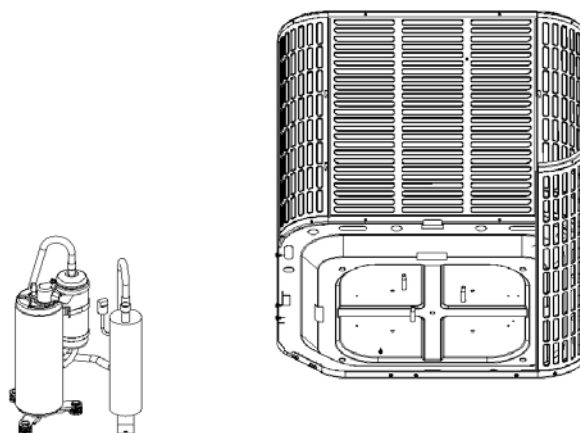

3.3.6 Exploded view and parts list

Exploded view and parts list of indoor unit.

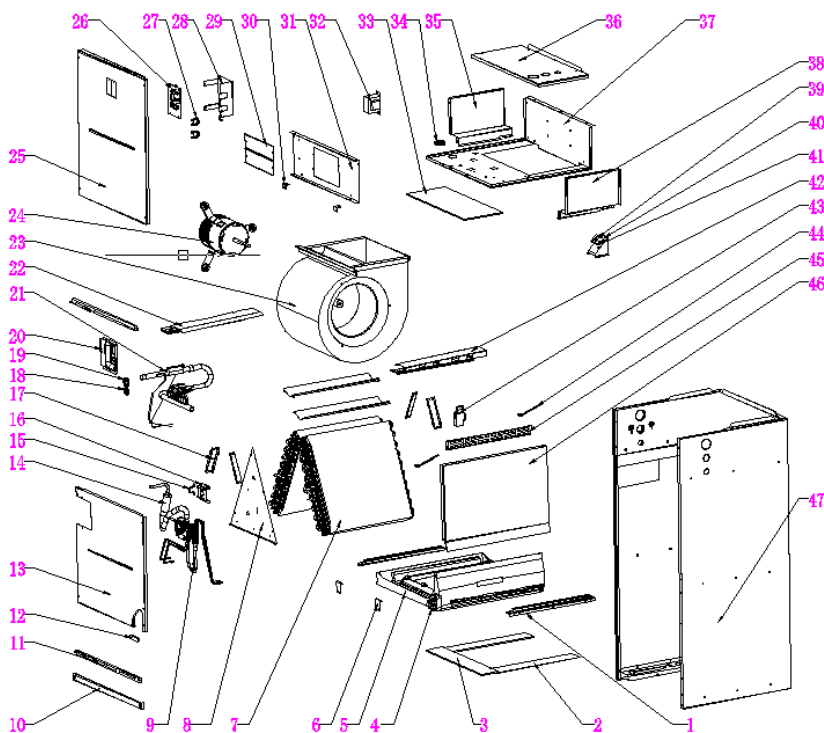

KIDT24H2-41X, KIDT36H2-41X				
No.	Part No.	Part Name	Q'ty	Remark
1	41214-000066	Welding component I for drip tray support plate	2	
2	42005-000926	Regular sponge	2	
3	42005-000911	Regular sponge	1	
4	41214-000783	Sealing plug for drip tray	3	
5	41308-000018	36K drip tray I	1	
6	41214-000262	Drip tray fixing hook	2	
7	92011-12633	Evaporator (expansion tube)	2	
8	41306-000370	Right connecting plate of evaporator (CNC)	1	
9	92002-000227	Distributor tube component	1	
10	41214-001811	Dust filter cover plate (CNC part)	1	
11	41214-000015	Support bar component (sprayed with sandpaper gray)	2	
12	42006-000038	Operation panel sponge	1	
13	41214-001804	Front side panel component (CNC part)	1	
14	92007-022132	Evaporator input pipe component	1	
15	41214-000316	Fixing plate II of thermal expansion valve	1	
16	41214-000315	Fixing plate I of thermal expansion valve	1	

17	41214-002386	Drip tray pull bar connecting plate (CNC)	2	
18	92012-000174	Pipe pressure plate through coil	1	
19	92012-000173	Pipe pressure plate through coil	1	
20	41214-001810	Piping cover component	1	
21	92007-021701	Evaporator output tube component	1	
22	41214-001530	Welding component I of wind wheel water blocking plate	1	
23	45008-000293	Wind wheel component	1	
24	22001-000656	Centrifugal fan motor	1	
25	43401-000055	Upper rear side panel components (CNC part)	1	
26	33402-000006	Control panel for household air conditioner	1	
27	41214-000519	Wire run-through clip	2	
28	41303-000163	Power board mounting panel (CNC)	1	
29	230803339	Electric auxiliary heat baffle	2	
30	230803338	Wind wheel fixing plate	2	
31	230803515	Air duct baffle	1	
32	230904118	Transformer	1	
33	42005-000896	Regular sponge	1	
34	42010-000006	Wire run-through rubber ring	1	
35	230803518	Air duct side baffle I	1	
36	43401-000056	Electric control cover plate component (CNC part)	1	
37	43401-000038	Air duct fixing plate (CNC)	1	
38	230803517	Air duct side baffle II	1	
39	11304-100097	Wiring terminals	1	
40	41211-000264	Wiring socket mounting panel	1	
41	230803113	Square grounding screw	1	
42	41214-001531	Wind wheel water blocking plate welding component II	1	
43	12412-100002	Gas sensor	1	
44	41214-002676	Drip tray pull rod (CNC)	2	
45	43401-000068	Support bar (CNC)	1	
46	41102-000277	Drip tray II	1	
47	41214-001802	Bottom tray component (CNC part)	1	

Exploded view and parts list of indoor unit.

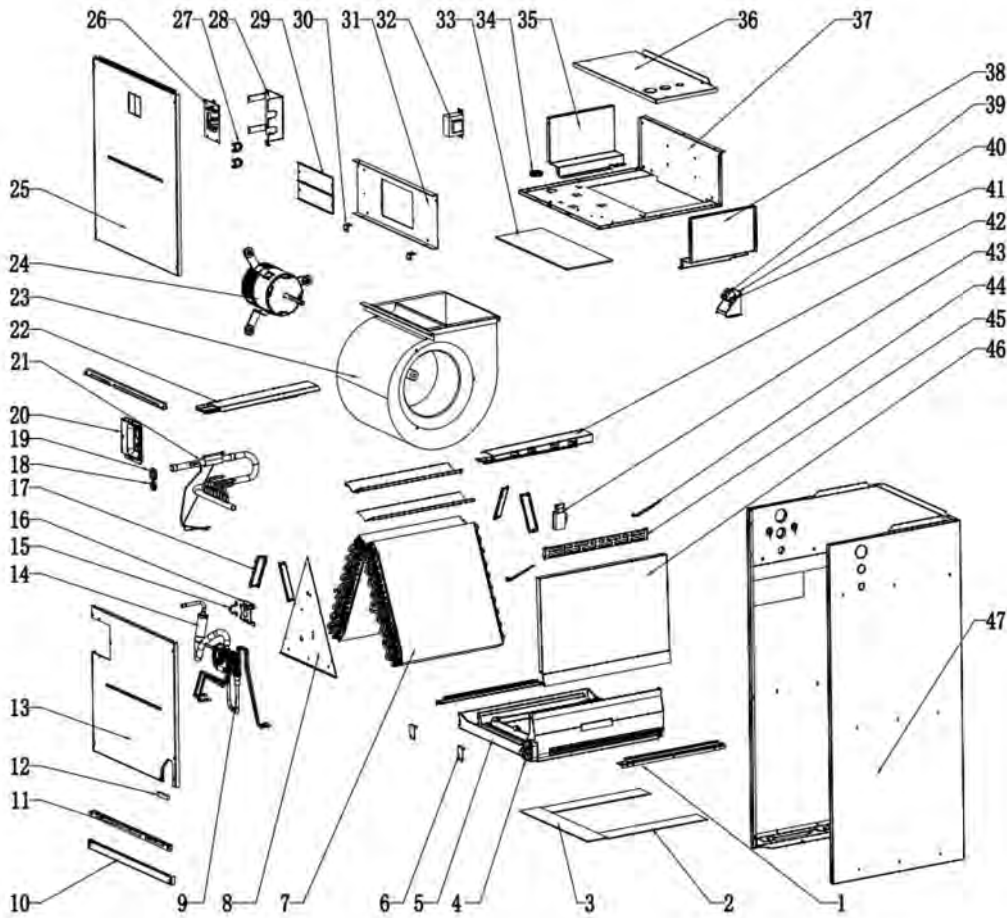

KIDT48H2-41X, KIDT60H2-41X				
No	Part No.	Part Name	Qty	Remark
1	43401-000084	Water pan support plate welding assembly	1	
2	42005-000893	Sponge	1	
3	42005-000894	Sponge	1	
4	41214-000783	Water pan sealing plug	3	
5	41308-000019	Drain tray	1	
6	41214-000262	Water plate fixing hook	2	
7	92011-012732	Evaporator	1	
8	41306-000372	Evaporator connector plate	1	
9	92007-022009	Input pipe of evaporator	1	
10	41214-001813	Dust screen cover plate	1	
11	41214-002417	Left supporter assembly	2	
12	42006-000038	Sponge	1	
13	43401-000053	Upper front panel assembly	1	
14	/	Input pipe of evaporator	1	
15	41214-000316	Thermal expansion valve fixed plate	1	
16	41214-000315	Thermal expansion valve fixed plate	1	
17	/	Water tray brace connecting plate	2	
18	92012-000173	Piping platen through coil	1	
19	92012-000174	Piping platen through coil	1	
20	41214-001810	Piping cover plate assembly	1	
21	92007-022007	Output pipe of evaporator	1	
22	/	Wind wheel water baffle I	1	

23	45008-000293	Vane	1	
24	22001-000657	Motor	1	
25	43401-000054	Side plate assembly	1	
26	G0301-113411	Controller board	1	
27	41214-000519	Line card	2	
28	41303-000137	Wiring clamp	1	
29	230803339	Electric auxiliary thermal baffle	2	
30	230803338	Wind wheel fixing plate	2	
31	/	Wheel baffle	1	
32	230904118	Transformer	1	
33	42005-000896	Sponge	1	
34	42010-000006	A line of synthetic	1	
35	230803336	Duct damper I	1	
36	43401-000057	Electronic control cover plate	1	
37	43401-000037	Duct components	1	
38	230803337	Duct damper II	1	
39	11304-100097	Terminal	1	
40	41211-000264	Electrical fixing board	1	
41	230803113	Grounding screw	1	
42	/	Wind wheel water baffle II	1	
43	12412-100002	Sensor	1	
44	/	Water tray brace	2	
45	43401-000068	Support	1	
46	/	Drain tray	1	
47	H0104-110032	Base	1	

Exploded view and parts list of outdoor unit

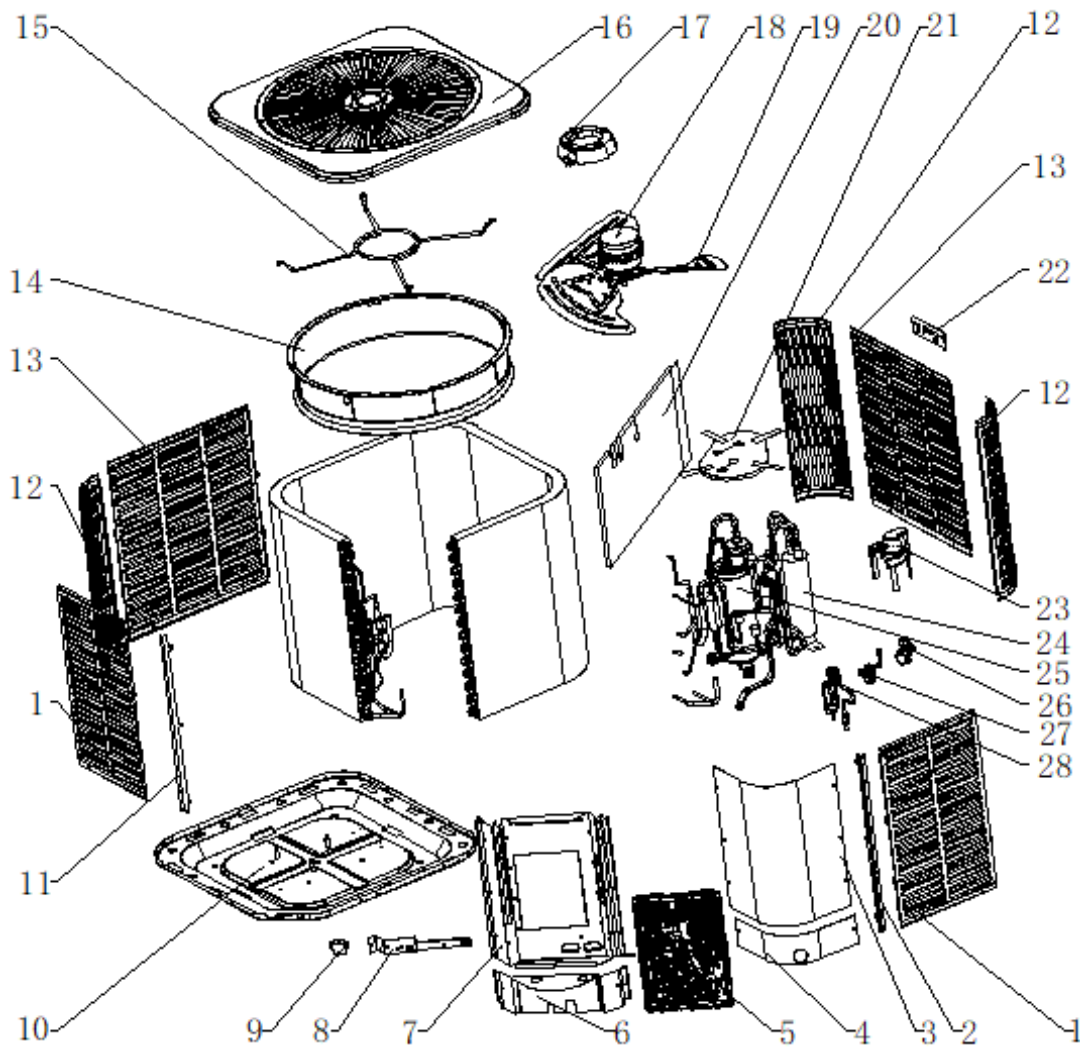

KOIT24H2-41G, KOIT36H2-41G				
No.	Part No.	Part Name	Q'ty	Remark
1	41214-002094	Side panel 1	2	
2	43301-000069	Right connecting plate (CNC)	1	
3	43301-000072	Electric control box cover component (CNC)	1	
4	43301-000070	Valve body cover plate (CNC)	1	
5	31201-003297	Electrical component	1	
6	43301-000051	Lower side panel	1	
7	43301-000053	Electric control mounting panel (upper panel) component	1	
8	43301-000067	Terminal bracket (CNC)	1	
9	11304-100125	Wiring terminals	1	
10	41202-000787	Bottom tray component	1	
11	43301-000068	Left connecting plate (CNC)	1	
12	43301-000047	Supporting column	3	
13	41214-002095	Side panel 2	2	
14	230700850	Wind guide ring	1	

15	230801628	Support frame	1	
16	41207-000829	Top cover component	1	
17	230803381	Motor support component	1	
18	25001-000428	Brushless DC motor	1	
19	45009-000057	Axial rolling fan blade	1	
20	92012-001135	Soundproofing cotton	1	
21	92012-001102	Soundproofing cotton	1	
22	43301-000062	Logo bracket	1	
23	42011-000599	Protective cover	1	
24	92003-000182	Gas liquid separator	1	
25	92014-001064	Compressor	1	
26	95002-001380	Low pressure shut-off valve	1	
27	92007-021888	High pressure valve component	1	
28	92007-011843	Electronic expansion valve component	1	

Exploded view and parts list of indoor unit.

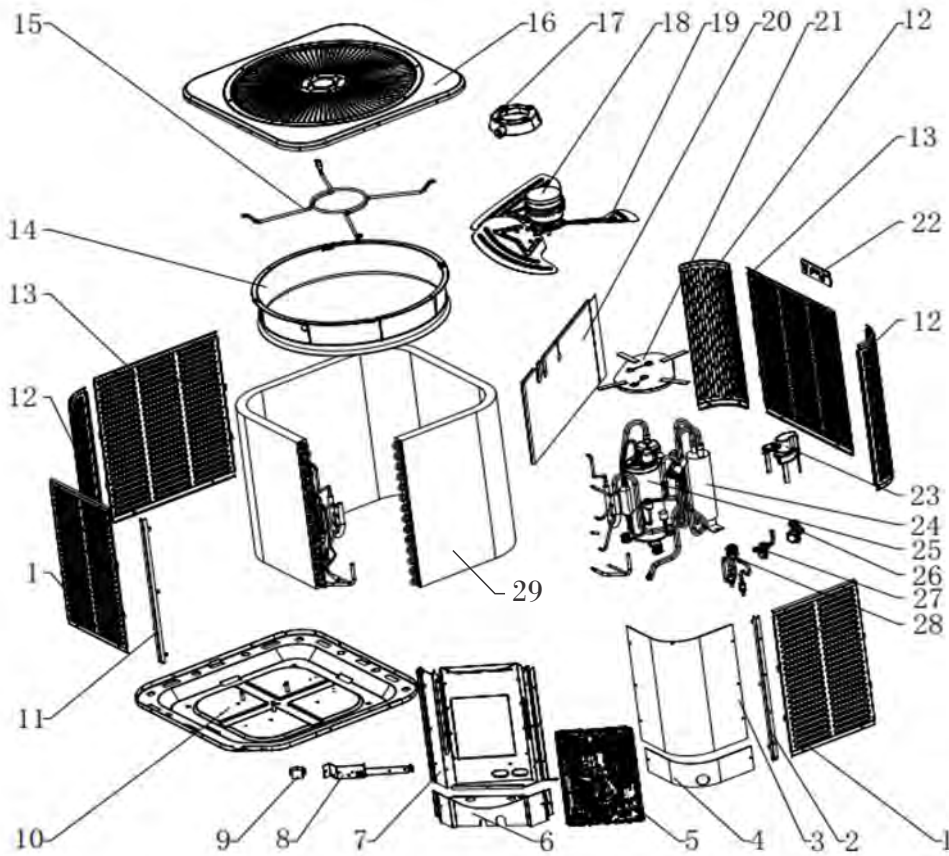

KOIT48H2-41G, KOIT60H2-41G				
No	New Code	Part name	Qty	Remark
1	41214-002416	Side panel	2	
2	230803302	Right connection plate	1	
3	45006-001825	Electrical box cover assembly	1	
4	H0203-110003	Electrical box cover	1	
5	31201-003241	Outdoor control assembly	1	
6	45003-000470	Lower side plate	1	
7	43301-000061	Electrically controlled mounting board	1	
8	43301-000067	Roof support frame	1	
9	11304-100125	Terminal	1	
10	41202-000662	Base	1	
11	43301-000073	Left connection plate	1	
12	43301-000048	Supporting board	3	
13	41214-002415	Side panel	2	
14	230700850	Wind deflector	1	
15	230801628	Support frame	1	
16	41207-000829	Top cover ass'y	1	
17	230803381	Motor stand	1	
18	25001-000428	Motor	1	
19	45009-000057	Propeller fan	1	
20 - 21	H2504-110064	Compressor sound insulation	1	
22	43301-000062	Roof support frame	1	
23	/	Shield	1	
24	92003-000183	Gas-liquid separator	1	
25	92014-001123	Compressor	1	

26	/	Valve body	1	
27	92007-021888	Valve assembly	1	
28	92007-022025	High-pressure valve ass'y	1	
29	92011-012515	Condenser	1	
	92007-022336	Condenser inlet pipe assembly	1	
	92007-022337	Condenser outlet pipe assembly	1	
	10104-100204	Sensor	1	
	92007-021826	Suction pipe ass'y	1	
	92009-002126	Connecting pipe assembly	1	
	92009-002129	Connecting pipe assembly	1	
	92007-022425	4-way valve assembly	1	

3.4 Appendices

3.4.1 Resistance/Temperature Lists of Temperature Sensors

1. Outdoor unit sensor temperature characteristic

TEMP (°F)	R min (kOhm)	R(t) (kOhm)	R max (kOhm)
-22.0	283.3	322.9	367.7
-20.2	267.4	304.4	346.3
-18.4	252.5	287.1	307.4
-16.6	238.5	270.9	307.4
-14.8	225.4	255.7	289.8
-13.0	213.1	241.4	273.3
-11.2	201.5	228	257.9
-9.4	190.6	215.5	243.4
-7.6	180.3	203.6	229.8
-5.8	170.7	192.5	217
-4.0	161.6	182.1	205
-2.2	153.1	172.3	193.7
-0.4	145	163.1	183.2
1.4	137.5	154.4	173.2
3.2	130.3	146.2	163.9
5.0	123.6	138.5	155.1
6.8	117.3	131.3	146.8
8.6	111.3	124.4	139
10.4	105.6	118	131.7
12.2	100.3	111.9	124.7
14.0	95.24	106.2	118.2
15.8	90.49	100.8	112.1
17.6	85.99	95.68	106.3
19.4	81.75	90.86	100.8
21.2	77.74	86.31	95.74
23.0	73.94	82.01	90.88
24.8	70.35	77.95	86.29
26.6	66.96	74.11	81.96
28.4	63.74	70.48	77.87
30.2	60.69	67.05	74.0
32.0	57.81	63.8	70.34
33.8	55.08	60.72	66.88
35.6	52.49	57.81	63.61
37.4	50.03	55.05	60.52
39.2	47.71	52.44	57.59
41.0	45.5	49.97	54.82
42.8	43.41	47.62	52.2

TEMP (°F)	R min (kOhm)	R(t) (kOhm)	R max (kOhm)
75.2	19.36	20.89	22.52
77.0	18.55	20	21.54
78.8	17.77	19.14	20.6
80.6	17.03	18.32	19.7
82.4	16.32	17.55	18.85
84.2	15.65	16.81	18.04
86.0	15	16.1	17.27
87.8	14.39	15.43	16.54
89.6	13.81	14.79	15.34
91.4	13.25	14.18	15.17
93.2	12.72	13.6	14.54
95.0	12.21	13.05	13.93
96.8	11.72	12.52	13.36
98.6	11.26	12.01	12.81
100.4	10.82	11.53	12.29
102.2	10.29	11.07	11.78
104.0	9.986	10.63	11.31
105.8	9.6	10.21	10.85
107.6	9.231	9.813	10.42
109.4	8.878	9.43	10
111.2	8.54	9.064	9.612
113.0	8.217	8.714	9.233
114.8	7.908	8.38	8.872
116.6	7.612	8.06	8.526
118.4	7.328	7.754	8.196
120.2	7.057	7.461	7.88
122.0	6.797	7.18	7.578
123.8	6.548	6.912	7.289
125.6	6.309	6.655	7.013
127.4	6.08	6.409	6.748
129.2	5.861	6.173	6.495
131.0	5.651	5.947	6.253
132.8	5.449	5.73	6.02
134.6	5.255	5.522	5.798
136.4	5.07	5.323	5.585
138.2	4.891	5.132	5.381
140.0	4.72	4.949	5.101

TEMP (°F)	R min (kOhm)	R(t) (kOhm)	R max (kOhm)
172.4	2.563	2.654	2.745
174.2	2.481	2.567	2.654
176.0	2.402	2.484	2.567
177.8	2.327	2.404	2.483
179.6	2.254	2.327	2.401
181.4	2.183	2.253	2.323
183.2	2.115	2.182	2.248
185.0	2.05	2.113	2.176
186.8	1.985	2.047	2.109
188.6	1.922	1.983	2.045
190.4	1.861	1.922	1.983
192.2	1.802	1.862	1.923
194.0	1.746	1.805	1.865
195.8	1.692	1.75	1.809
197.6	1.639	1.697	1.755
199.4	1.589	1.646	1.703
201.2	1.54	1.596	1.653
203.0	1.493	1.549	1.604
204.8	1.448	1.502	1.558
206.6	1.404	1.458	1.512
208.4	1.362	1.415	1.469
210.2	1.321	1.373	1.426
212.0	1.284	1.335	1.387
213.8	1.245	1.296	1.348
215.6	1.209	1.258	1.309
217.4	1.173	1.222	1.272
219.2	1.139	1.187	1.236
221.0	1.105	1.153	1.202
222.8	1.073	1.12	1.168
224.6	1.042	1.089	1.136
226.4	1.013	1.058	1.104
228.2	0.9833	1.028	1.074
230.0	0.9553	0.9997	1.045
231.8	0.9283	0.9719	1.016
233.6	0.9021	0.9451	0.9892
235.4	0.8765	0.9191	0.9626
237.2	0.8524	0.894	0.9367

44.6	41.42	45.4	49.71
46.4	39.53	43.2	42.33
48.2	37.74	41.29	45.12
50.0	36.04	39.39	43.01
51.8	34.42	37.59	41
53.6	32.89	35.87	39.1
55.4	31.43	34.25	37.29
57.2	30.04	32.71	35.58
59.0	29.72	31.24	33.95
60.8	28.31	30.72	31.82
62.6	26.87	29.21	30.72
64.4	25.13	27.26	29.55
66.2	24.05	26.07	28.23
68.0	23.02	24.93	26.97
69.8	22.04	23.84	25.77
71.6	21.1	22.81	24.63
73.4	20.21	21.83	23.55

141.8	4.556	4.774	4.997
143.6	4.398	4.605	4.817
145.4	4.247	4.448	4.644
147.2	4.101	4.288	4.479
149.0	3.961	4.139	4.32
150.8	3.827	3.995	4.167
152.6	3.698	3.858	4.021
154.4	3.552	3.712	3.883
156.2	3.410	3.692	3.742
158.0	3.339	3.476	3.616
159.8	3.229	3.359	3.491
161.6	3.122	3.246	3.372
163.4	3.02	3.138	3.257
165.2	2.921	3.033	3.146
167.0	2.827	2.933	3.04
168.8	2.735	2.836	2.938
170.6	2.647	2.743	2.84

239.0	0.8087	0.8595	0.9117
240.8	0.8059	0.8461	0.8875
242.6	0.7837	0.8233	0.8641
244.4	0.7623	0.8012	0.8413
246.2	0.7415	0.7798	0.8193
248.0	0.7201	0.7581	0.7910
249.8	0.702	0.7386	0.7773
251.6	0.6631	0.7195	0.7572
253.4	0.6649	0.7007	0.7378
255.2	0.6472	0.6824	0.7189
257.0	0.6301	0.6647	0.7006
258.8	0.6135	0.6476	0.6829
260.6	0.5974	0.6309	0.6657
262.4	0.5818	0.6148	0.649
264.2	0.5667	0.5991	0.6328
266.0	0.5521	0.5839	0.6171

R—Resistance
Resistance at 77°F: 20 kΩ

TH3: Outdoor unit discharge pipe sensor
Before measuring resistance, disconnect connectors as shown above.

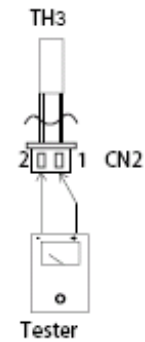

2. Indoor unit sensor temperature characteristics

Temp (°C)	resistance(KΩ)			resist. tolerance %	
	Rmax	R(t)Normal	Rmin	MAX(+)	MIN(-)
-40	122.059	113.858	106.153	7.20	6.77
-39	114.913	107.292	100.128	7.10	6.68
-38	108.234	101.150	94.488	7.00	6.59
-37	101.988	95.402	89.204	6.90	6.50
-36	96.145	90.020	84.253	6.80	6.41
-35	90.675	84.979	79.611	6.70	6.32
-34	85.553	80.254	75.256	6.60	6.23
-33	80.754	75.823	71.170	6.50	6.14
-32	76.256	71.667	67.333	6.40	6.05
-31	72.038	67.766	63.729	6.30	5.96
-30	68.080	64.104	60.343	6.20	5.87
-29	64.375	60.666	57.157	6.11	5.78
-28	60.870	57.413	54.139	6.02	5.70
-27	57.579	54.355	51.301	5.93	5.62
-26	54.487	51.480	48.630	5.84	5.54

-25	51.582	48.776	46.115	5.75	5.46
-24	48.850	46.232	43.748	5.66	5.37
-23	46.279	43.836	41.517	5.57	5.29
-22	43.861	41.581	39.415	5.48	5.21
-21	41.585	39.456	37.432	5.40	5.13
-20	39.462	37.473	35.581	5.31	5.05
-19	37.421	35.565	33.798	5.22	4.97
-18	35.519	33.785	32.134	5.13	4.89
-17	33.725	32.105	30.561	5.05	4.81
-16	32.033	30.520	29.077	4.96	4.73
-15	30.437	29.023	27.673	4.87	4.65
-14	28.931	27.609	26.347	4.79	4.57
-13	27.508	26.273	25.092	4.70	4.49
-12	26.165	25.010	23.905	4.62	4.42
-11	24.896	23.816	22.782	4.53	4.34
-10	23.697	22.687	21.720	4.45	4.26
-9	22.562	21.618	20.71	4.37	4.19
-8	21.490	20.607	19.759	4.29	4.11
-7	20.475	19.649	18.855	4.21	4.04
-6	19.515	18.742	17.999	4.13	3.97
-5	18.606	17.883	17.187	4.05	3.89
-4	17.745	17.068	16.416	3.97	3.82
-3	16.930	16.296	15.685	3.89	3.75
-2	16.156	15.563	14.991	3.81	3.68
-1	15.423	14.868	14.332	3.73	3.61
0	14.792	14.270	13.766	3.66	3.54
1	14.069	13.582	13.111	3.58	3.47
2	13.443	12.987	12.546	3.51	3.40
3	12.849	12.422	12.008	3.43	3.33
4	12.284	11.885	11.497	3.36	3.26
5	11.749	11.375	11.012	3.29	3.19
6	11.239	10.889	10.548	3.22	3.13
7	10.756	10.428	10.109	3.15	3.06
8	10.295	9.988	9.689	3.08	3.00
9	9.858	9.570	9.289	3.01	2.93
10	9.441	9.172	8.909	2.94	2.87
11	9.044	8.792	8.545	2.87	2.81
12	8.667	8.431	8.199	2.80	2.75
13	8.308	8.087	7.870	2.74	2.69
14	7.965	7.758	7.554	2.67	2.62
15	7.639	7.445	7.254	2.61	2.56
16	7.329	7.147	6.968	2.54	2.51
17	7.032	6.862	6.694	2.48	2.45
18	6.749	6.590	6.433	2.42	2.39
19	6.480	6.331	6.183	2.36	2.33
20	6.223	6.083	5.945	2.30	2.27

21	5.977	5.846	5.716	2.23	2.22
22	5.742	5.620	5.498	2.18	2.16
23	5.518	5.404	5.290	2.12	2.11
24	5305	5.198	5.091	2.06	2.05
25	5.100	5.000	4.900	2.00	2.00
26	4.909	4.811	4.713	2.05	2.04
27	4.727	4.630	4.533	2.09	2.09
28	4.552	4.457	4.36	2.14	2.13
29	4.386	4.292	4.199	2.18	2.17
30	4.225	4.133	4.042	2.23	2.21
31	4.072	3.982	3.892	2.27	2.25
32	3.925	3.836	3.748	2.31	2.29
33	3.784	3.697	3.611	2.36	2.33
34	3.649	3.564	3.479	2.40	2.37
35	3.520	3.436	3353	2.44	2.41
36	3.395	3.313	3.232	2.48	2.45
37	3.275	3.195	3.116	2.52	2.49
38	3.161	3.082	3.004	2.56	2.52
39	3.051	2.974	2.898	2.60	2.56
40	2.946	2.870	2.795	2.64	2.60
41	2.844	2.770	2.697	2.68	2.63
42	2.748	2.675	2.604	2.71	2.67
43	2.654	2.583	2.513	2.75	2.71
44	2.564	2.494	2.426	2.79	2.74
45	2.478	2.410	2.343	2.83	2.78
46	2.395	2.328	2.263	2.86	2.81
47	2.315	2.250	2.186	2.90	2.84
48	2.238	2.174	2.111	2.93	2.88
49	2.164	2.102	2.041	2.97	2.91
50	2.093	2.032	1972	3.01	2.95
51	2.025	1.965	1.906	3.04	2.98
52	1.959	1.901	1.844	3.07	3.01
53	1.896	1.839	1.783	3.11	3.04
54	1.835	1.779	1.724	3.14	3.07
55	1.776	1.721	1.668	3.18	3.11
56	1.719	1.666	1.614	3.21	3.14
57	1.665	1.613	1.562	3.24	3.17
58	1.613	1.562	1.512	3.27	3.20
59	1.562	1.512	1.463	3.31	3.23
60	1.514	1.465	1.417	3.34	3.26
61	1.467	1.419	1.372	3.37	3.29
62	142	1.374	1.328	3.40	3.32
63	1.378	1.332	1.287	3.43	3.35
64	1.334	1.291	1.247	3.46	3.38
65	1.295	1.25	1.208	3.49	3.41
66	1.256	1.213	117	3.52	3.43

67	1.218	1.176	1135	3.55	3.46
68	1.181	1140	1.100	3.58	3.49
69	1.146	1.106	1.067	3.61	3.52
70	1.112	1.073	1.035	3.64	3.55
71	1079	1.041	1.004	3.67	3.57
72	1.045	1.010	0.974	3.70	3.60
73	1.016	0.980	0.944	3.72	3.63
74	0.988	0.952	0.917	3.75	3.65
75	0.959	0.924	0.890	3.78	3.68
76	0.931	0.897	0.864	3.80	3.71
77	0.904	0.87	0.839	3.83	3.73
78	0.879	0.846	0.814	3.86	3.76
79	0854	0.82	0.79	3.88	3.78
80	0.830	0.799	0.769	3.91	3.81
81	0.807	0.776	0.746	3.94	3.83
82	0.784	0.754	0725	3.96	3.85
83	0.762	0.733	0.705	3.99	3.88
84	0742	0.713	0.685	4.0	3.90
85	0.721	0.693	0.666	4.03	3.92
86	0.70	0.674	0647	4.06	3.95
87	0.682	Q.655	0.629	4.08	3.97
88	0.664	0.638	0.613	4.10	3.99
89	0.646	0.620	0.595	4.13	4.01
90	0.629	0.604	0.580	4.15	4.03
91	0.611	0.587	0.563	4.17	4.05
92	0.596	0.572	0.549	4.19	4.07
93	0.580	0.557	0.534	4.21	4.09
94	0.565	0.542	0.520	4.23	4.11
95	0.550	0.528	0.506	4.25	4.13
96	0.536	0.514	0.493	4.27	4.15
97	0.522	0.501	0.480	4.29	4.17
98	0.50g	0.488	0.468	4.31	4.18
99	0.491	0.476	0.456	4.33	4.20
100	0.48	0.464	0.444	4.34	4.22
101	0.472	0.452	0.433	4.36	4.23
102	0.460	0441	0.422	4.38	4.25
103	0.449	0.430	0.412	4.39	4.26
104	0.43	0419	0.401	4.41	4.28
105	0.427	0.409	0.391	4.42	4.29
106	0.416	0.399	0.381	4.44	4.31

3.4.2 Temperature / Pressure list of Refrigerant

	24K			36K			60K		
	f(Hz)	HP (MPa)	LP (MPa)	f(Hz)	HP (MPa)	LP (MPa)	f(Hz)	HP (MPa)	LP (MPa)
35°C (95°F) Cooling	72	2.92	0.93	76	2.62	0.82	84	3.05	0.76
43°C (109.4°F) Cooling	66	3.32	1.05	70	3.01	0.87	72	3.38	0.84
48°C (118.4°F) Cooling	54	3.50	1.14	64	3.28	1.08	64	3.71	1.01
7°C (44.6°F) Heating	72	2.20	0.65	86	2.38	0.60	86	2.99	0.61
20°C (68°F)Heating	60	2.02	0.69	74	2.69	0.78	70	2.52	0.73
Rated Cooling	52	2.67	1.01	72	2.57	0.85	84	3.05	0.76
Rated Heating	66	2.14	0.66	74	2.47	0.61	76	2.40	0.56

NOTE

The test under condition:

Rated Cooling: IDU dry bulb 26.7°C/80°F Wet bulb 19.4°C/67°F, ODU dry bulb 35°C/95°F wet bulb 23.9°C/75°F; The connection pipes: 7.5m/24.6 ft.

Rated Heating: IDU dry bulb 21.1°C/70°F Wet bulb 15.6°C/60°F , ODU dry bulb 8.3°C/47°F wet bulb 6.1°C/43°F; The connection pipes: 7.5m/24.6 ft.

IMPORTANT

The above data under test standard in the lab, the HP (High pressure) and LP (Low pressure) will vary along with the variation of operation frequency, ambient temperature and/or fan speed.

3.4.3 Operation tools

The following tools will be used:

- 1) Liquid-level gauge;
- 2) Screwdriver;
- 3) Electric driven rotary hammer;
- 4) Drill;
- 5) Pipe expander;
- 6) Torque wrench;
- 7) Open-end wrench;
- 8) Pipe cutter;
- 9) Leak detector;
- 10) Vacuum pump;
- 11) Pressure gauge;
- 12) Universal meter;
- 13) Hexagon wrench;
- 14) Tapeline.

KLIMAIRE™ ≈

Mark of Superior Quality

7999 NW 81 Place Miami, FL 33195
Klimaïre Products Inc.

Tel: (305) 593 - 8358

E-mail: info@klimaïre.com

Website: www.klimaïre.com

Klimaïre parts and supplies are available online at: www.klimaïre.com

Scan the QR code
to visit our Help Center
for installation guides,
manuals, videos and more.



The Klimaïre logo is a registered Trademark of Klimaïre Products Inc.
Copyright 2026 Klimaïre Products Inc.

The design and specifications are subject to change without prior notice for
product improvement. Consult with the sales agency or manufacturer for details.