

EXPLODED DIAGRAM - PARTS VIEW

Sale Model: KWIO09-H2
Power Supply: 208-230V~ / 1ph / 60Hz

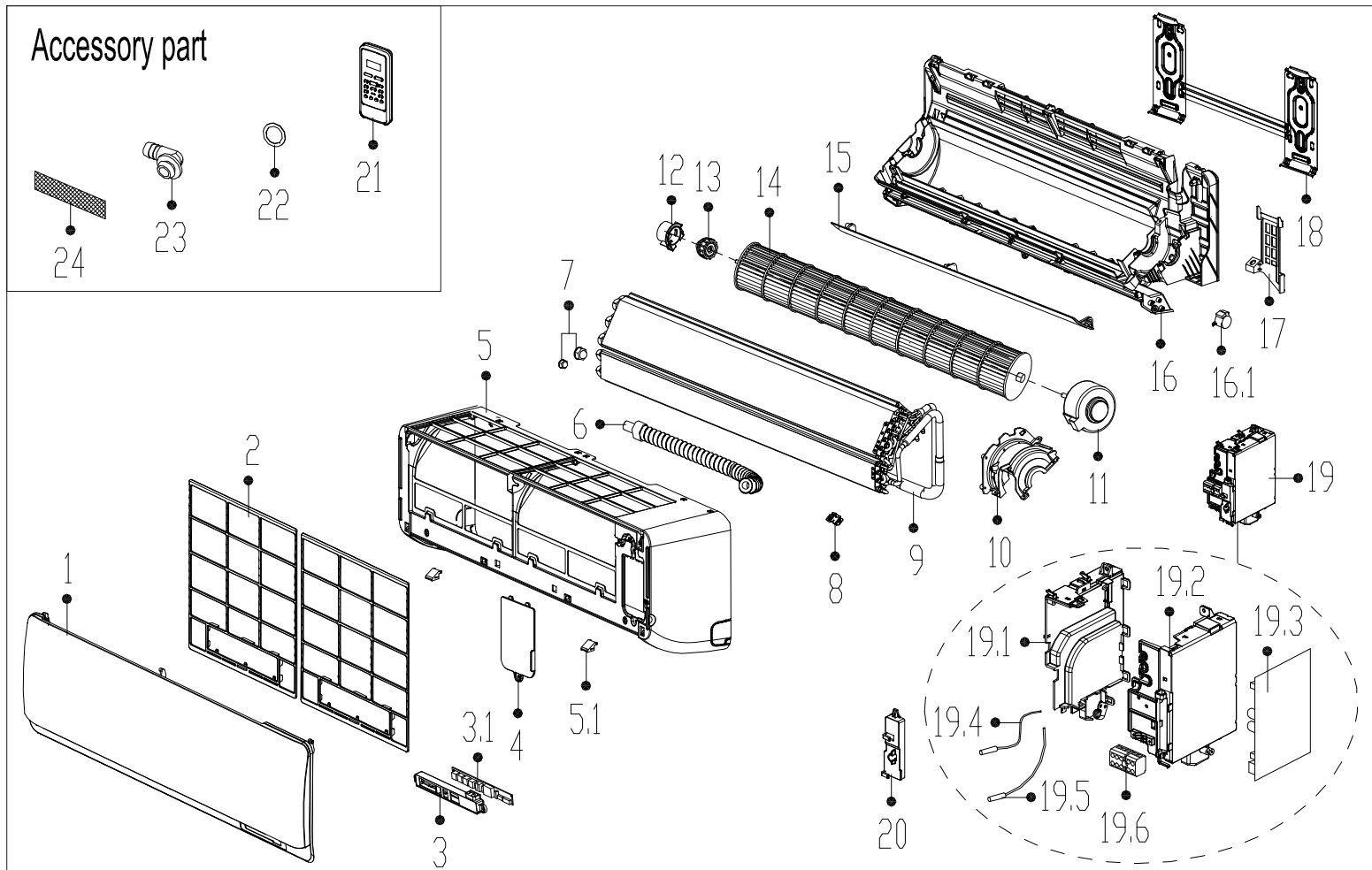

This information is to be used by qualified HVAC technicians only and is subject to revision without notice

KWIO09-H2- - Drawing No. D2IO1406

DATE 14-03

KWIO09-H2 - SPARE PARTS LIST

No.	Part Number	Part Name	Specifications	Stock No.	Qty.	Price	Remarks
1	2011325A5336	Panel assembly			1	\$58.52	
2	201132590962	Air filter			2	\$7.76	
3	2033325A1977	Display box assembly			1	\$32.06	
3.1	2013323A1250	Display board assembly			1	\$29.36	
4	201119901024	Cover of electrical equipment			1	\$5.45	
5	201132591059	Panel frame assembly			1	\$58.52	
5.1	201119900950	Screw cap			2	\$0.33	
6	201101020038	Drain hose			1	\$6.11	
7	201600320001	Pipe nut			1	\$0.66	
7	201600320000	Pipe nut			1	\$0.33	
8	201102000305	Fix clamp of temperature sensor			1	\$0.33	
9	201532590453	Evaporator assembly			1	\$256.97	
10	201132490127	Fan motor cover			1	\$6.11	
11	202400370022	Brushless DC Motor			1	\$222.84	WZDK20-38G
12	201119900952	Bearing holder			1	\$0.83	
13	202719900606	Bearing base			1	\$2.15	
14	201100200054	Cross flow fan			1	\$58.52	
15	201132590956	Horizontal louver			1	\$15.30	
16	201132590963	Chassis assembly			1	\$113.30	
16.1	202400200031	Louver motor			1	\$15.90	
17	201119900949	Pipe clamp board			1	\$1.16	
18	201232590037	Installation plate			1	\$14.40	
19	203332391211	Electronic control box assembly			1	\$152.10	
19.1	201132490125	Electronic control box I			1	\$9.74	

This information is to be used by qualified HVAC technicians only and is subject to revision without notice

KWIO09-H2 - Parts List No. P2IO1406

Above prices are subject to S&H charges

DATE 14-03

KWIO09-H2 - SPARE PARTS LIST

No.	Part Number	Part Name	Specifications	Stock No.	Qty.	Price	Remarks
19.2	201132490139	Electronic control box II			1	\$12.90	
19.3	201332391798	Indoor main control board assembly			1	\$120.78	
19.4	202432390005	Ambient temperature sensor assembly			1	\$4.95	
19.5	202301300584	Pipe temperature sensor assembly			1	\$7.10	
19.6	202301400488	Wire joint			1	\$10.50	
20	201132490126	Cover of electronic control box			1	\$1.32	
21	2033550B0251	Remote Controller			1	\$58.52	
22	202720090001	Seal ring			1	\$0.33	
23	201101020011	Drain joint			1	\$0.50	
24	201131410703	Air freshening filter			1	\$1.49	

This information is to be used by qualified HVAC technicians only and is subject to revision without notice

KWIO09-H2 - Parts List No. P2IO1406

Above prices are subject to S&H charges

DATE 14-03