

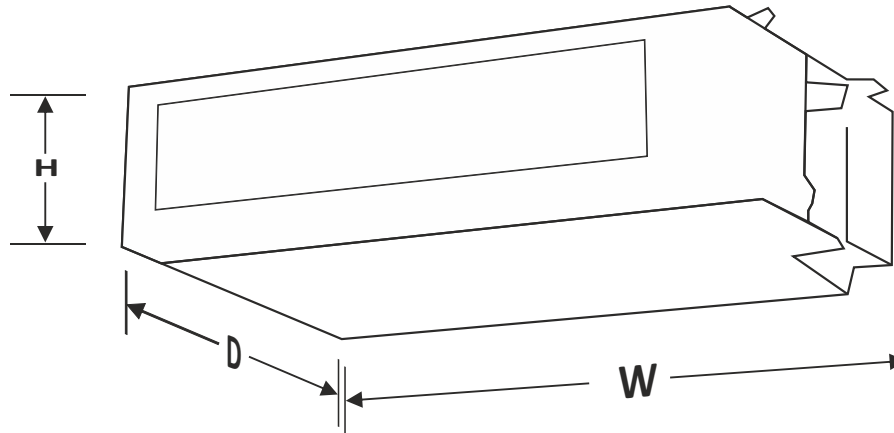

## KDIR - Technical Specifications

### KDIR Series Indoor Units

KDIR Series Ducted Recessed Fan Coil Unit			KDIR09-H2	KDIR12-H2	KDIR18-H2	KDIR24-H2
Power supply		V-ph-Hz	208-230~1-60	208-230~1-60	208-230~1-60	208-230~1-60
Capacity	Cooling	Btu/h	9000	12000	18000	24000
	Heating @ 47 °F	Btu/h	10000	12000	18000	24400
Performance	Air flow (Hi/Med/Lo) - No duct	cfm	335/290/240	370/320/260	520/430/360	820/620/520
	Noise Level - dB(A)	Hi/Med/Lo	38/35/31	44/37/31	41/39/37	53/48/43
Dimensions & Weight	Unit Dimensions - W*D*H	in	27.56x25x8.27	27.56x25x8.27	36.22x25x8.27	36.22x25x10.63
	Net/Gross weight	lb	39.90/50.27	42.11/51.59	50.71/60.63	57.32/68.34
Refrigerant Piping	Liquid side/ Gas side	in	1/4" / 3/8"	1/4" / 1/2"	1/4" / 1/2"	3/8" / 5/8"



Continued product improvement is our goal at Klimate Products, Inc. Hence, specifications and data listed herein are subject to change without notice and without obligation on our part. Always comply with local, state, and national electrical codes.

1. - The above design and specifications are subject to change without prior notice for product improvement.
2. - The values given in the table for the noise level reflect the levels in anechoic chamber.